



# **Hydraulic Motor/Pump Series F11/F12**

*Fixed Displacement*

*Catalogue HY17-8249/UK  
March 2004*



<b>Conversion</b>	<b>factors</b>
1 kg .....	2.20 lb
1 N.....	0.225 lbf
1 Nm.....	0.738 lbf ft
1 bar .....	14.5 psi
1 l .....	0.264 US gallon
1 cm <sup>3</sup> .....	0.061 cu in
1 mm .....	0.039 in
$\frac{9}{5}^{\circ}\text{C} + 32$ .....	1 $^{\circ}\text{F}$

<b>Content</b>	<b>Page</b>
General information .....	4
F11 cross section .....	4
F12 cross sections .....	5
Specifications .....	6
Ordering codes	
F11-CETOP .....	7
F11-ISO .....	8
F11-SAE .....	9
F12-ISO .....	10
F12-Cartridge .....	11
F12-SAE .....	12
Preferred versions F11/F12 .....	13
Technical information	
Bearing life .....	14
Bearing life calculation .....	14
Required information .....	14
Efficiency .....	15
Noise level .....	15
Selfpriming speed and required inlet pressure .....	16
Installation dimensions	
F11-5 CETOP .....	17
F11-10 CETOP .....	18
F11-14 CETOP .....	19
F11-19 CETOP .....	20
F11-14 ISO .....	21
F11-14 SAE .....	22
F11-19 SAE .....	23
F12-30, -40, -60, -80 and -110 ISO .....	24-25
F12-30, -40, -60, -80 and -110 Cartridge .....	26-27
F12-30, -40, -60, -80 and -110 SAE 4 bolt flange ....	28-29
F12-30, -40, and -60 SAE 2 bolt flange .....	30-31
F11-150 CETOP .....	32
F11-150 SAE .....	33
F11-250 SAE .....	34
Technical information	
F11 saw motors .....	35
F11 fan motors .....	35
F12 integrated flushing valve .....	36
F12 accessory valve blocks .....	36
Type BT brake valve .....	37
Type SR pressure relief/make-up valve .....	37
Type SV pressure relief valve .....	38
Speed sensor .....	38
F12 main port suction fittings .....	39
Suction fittings .....	39
Suction fitting kits .....	39
Split-flange kits .....	39
Installation information	
Direction of rotation .....	40
Hydraulic fluids .....	40
Operating temperature .....	40
Viscosity .....	41
Filtration .....	41
Case pressure .....	41
Before start-up .....	42
Case drain connections .....	42

F11 and F12 are bent axis, fixed displacement heavy-duty motor/pump series. They can be used in numerous applications in both open and closed loop circuits.

- Series F11 is available in the following frame sizes and versions:
  - F11-5, -10, -14, 19 and -150 with CETOP mounting flange and shaft end
  - F11-14 with ISO flange and shaft
  - F11-14, -19, -150 and -250 with SAE flange and shaft
- Series F12 conforms to current ISO and SAE mounting flange and shaft end configurations. A very compact cartridge version is also available.
- Thanks to the unique spherical piston design, F11/F12 motors can be used at unusually high shaft speeds. Operating pressures to 480 bar provides for the high output power capability.
- The 40° angle between shaft and cylinder barrel allows for a very compact, lightweight motor/pump.

- The laminated piston ring offers important advantages such as low internal leakage and thermal shock resistance.
- The pump version has highly engineered valve plates for increased selfpriming speed and low noise, available with left and right hand rotation.
- The F11/F12 motors produce very high torque at start-up as well as at low speeds.
- Our unique timing gear design synchronizes shaft and cylinder barrel, making the F11/F12 very tolerant to high 'G' forces and torsional vibrations.
- Heavy duty roller bearings permit substantial external axial and radial shaft loads.
- The F11's and F12's have a simple and straightforward design with very few moving parts, making them very reliable motors/pumps.
- The unique piston locking, timing gear and bearing set-up as well as the limited number of parts add up to a very robust design with long service life and, above all, proven reliability.

**F11 cross section**

1. Barrel housing
2. Valve plate
3. Cylinder barrel
4. Guide spacer with O-rings
5. Timing gear
6. Roller bearing
7. Bearing housing
8. Shaft seal
9. Output/input shaft
10. Piston with laminated piston ring

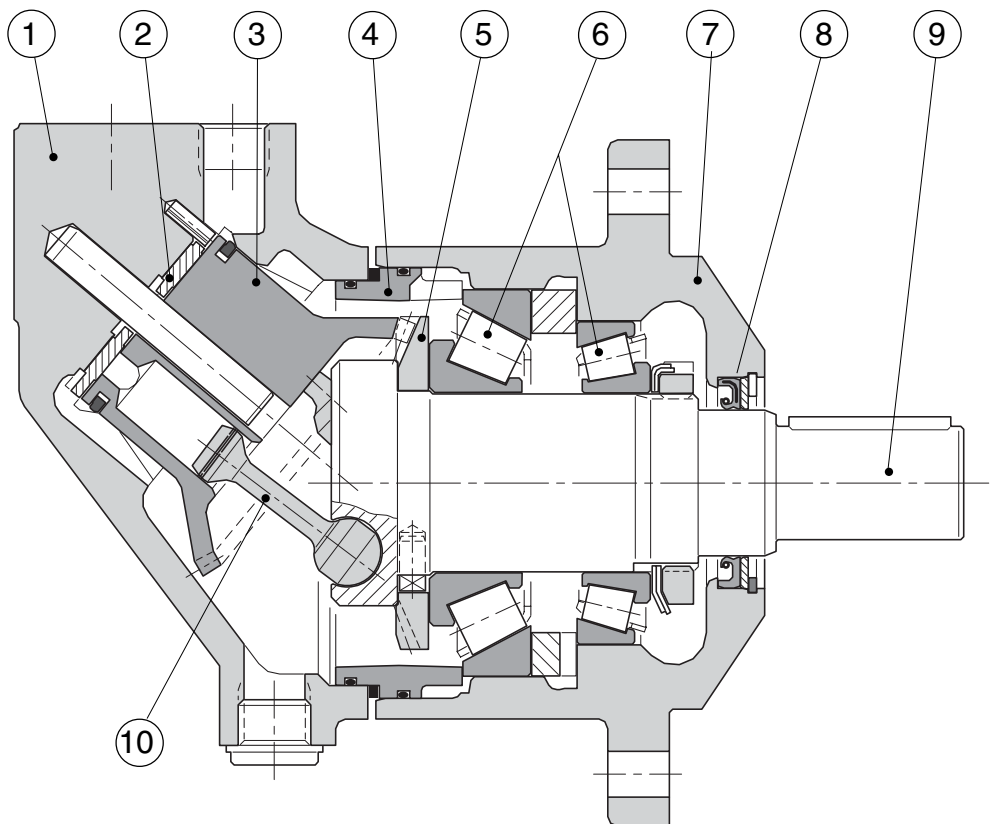

**F12 cross sections**

**F12-30, -40, -60 and -80**  
 (F12-60 shown)

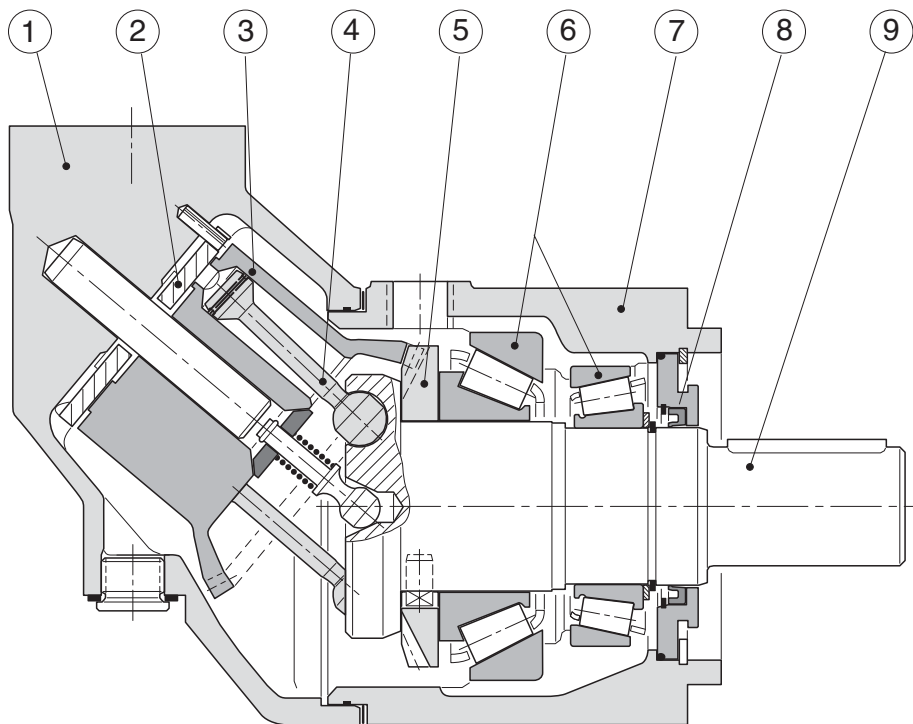

- Legend:
- |                            |                            |                               |
|----------------------------|----------------------------|-------------------------------|
| 1. Barrel housing          | 5. Timing gear             | 9. Output/input shaft         |
| 2. Valve plate             | 6. Tapered roller bearings | 10. Port E (F12-110)          |
| 3. Cylinder barrel         | 7. Bearing housing         | 11. Needle bearings (F12-110) |
| 4. Piston with piston ring | 8. Shaft seal              |                               |

**F12-110**

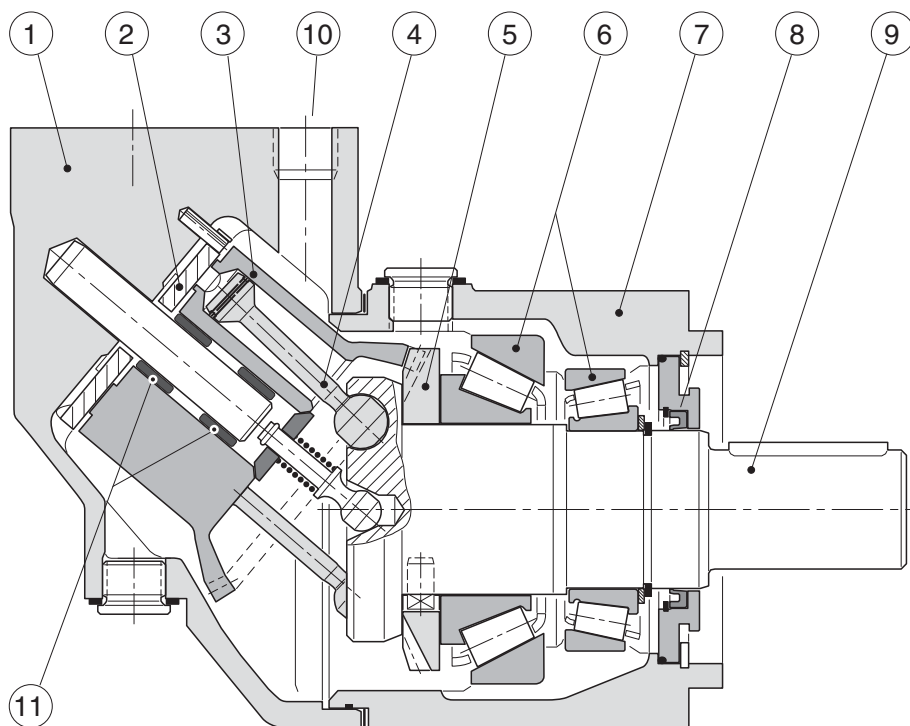

**Specifications**

Frame size	F11-5	-10	-14	-19	F12-30	-40	-60	-80	-110	F11-150	-250	
<b>Displacement</b> [cm <sup>3</sup> /rev]	4.9	9.8	14.3	19.0	30.0	40.0	59.8	80.4	110.1	150	242	
<b>Operating pressure</b>												
max intermittent <sup>1)</sup> [bar]	420	—————			420	480	—————			480	420	420
max continuous [bar]	350	—————			350	420	—————			420	350	350
<b>Motor operating speed</b> [rpm]												
max intermittent <sup>1)</sup>	12 000	11 000	10 000	9 000	7 100	6 400	5 600	5 200	4 700	3 000	2 700	
max continuous	10 800	9 900	9 000	8 100	5 600	5 000	4 300	4 000	3 600	2 600	2 400	
min continuous	50	—————			—————					————— 50		
<b>Max pump selfpriming speed<sup>2)</sup></b>												
L or R function; max [rpm]	4 600	4 200	3 900	3 500	3 150	2 870	2 500	2 300	2 290	1 700	1 500	
<b>Motor input flow</b>												
max intermittent <sup>1)</sup> [l/min]	58	108	143	171	213	256	335	418	517	450	650	
max continuous [l/min]	52	97	128	153	168	200	257	322	396	390	580	
<b>Main circuit temp.<sup>3)</sup>, max</b> [°C]	80											
min [°C]	-35	-35	-30	-35	-35					-35		
<b>Mass moment of inertia</b>												
(x10 <sup>-3</sup> ) [kg m <sup>2</sup> ]	0.16	0.39	0.42	1.1	1.7	2.9	5	8.4	11.2	40	46	
<b>Weight</b> [kg]	5	7.5	8.3	11	12	16.5	21	26	36	70	77	

- 1) Intermittent: max 6 seconds in any one minute.
- 2) Selfpriming speed valid at sea level.
- 3) See also installation information, operating temperature.

**Basic formulas for hydraulic motors**

Flow (q)

$$q = \frac{D \times n}{1000 \times \eta_v} \text{ [l/min]}$$

D - displacement [cm<sup>3</sup>/rev]

n - shaft speed [rpm]

$\eta_v$  - volumetric efficiency

$\Delta p$  - differential pressure [bar]  
(between inlet and outlet)

$\eta_{hm}$  - mechanical efficiency

$\eta_t$  - overall efficiency

( $\eta_t = \eta_v \times \eta_{hm}$ )

Torque (M)

$$M = \frac{D \times \Delta p \times \eta_{hm}}{63} \text{ [Nm]}$$

Power (P)

$$P = \frac{q \times \Delta p \times \eta_t}{600} \text{ [kW]}$$

**Ordering codes**

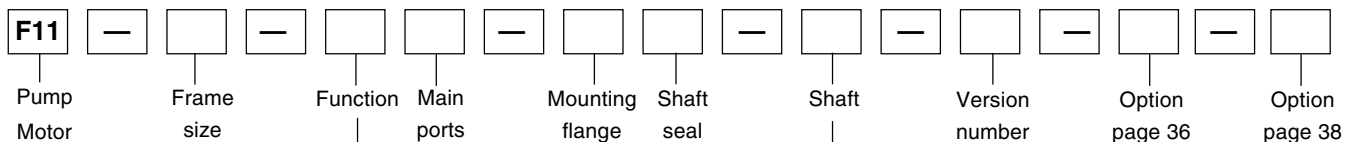

**F11-CETOP**

Frame size	
Code	Displacem. (cm <sup>3</sup> /rev)
5	4.9
10	9.8
14	14.3
19	19.0
150	150.0

Version number
(assigned for special versions)

Option
None

Frame size	5	10	14	19	150
<b>Code Function</b>					
<b>M</b> Motor	x	x	-	x	x
<b>H</b> Motor, high pressure	x	x	x	x	x
<b>Q</b> Motor, silent	(x)	(x)	-	(x)	(x)
<b>J</b> Motor, clockwise rot'n <sup>1)</sup>	(x)	(x)	-	(x)	(x)
<b>G</b> Motor, counter clockw. <sup>1)</sup>	(x)	(x)	-	(x)	(x)
<b>R</b> Pump, clockwise rot'n	x	x	x	x	x
<b>L</b> Pump, counter clockw.	x	x	x	x	x

Frame size	5	10	14	19	150
<b>Code Shaft</b>					
<b>K</b> Metric key	x	x	x	x	x
<b>D</b> Spline, DIN 5480	(x)	(x)	(x)	(x)	(x)

Frame size	5	10	14	19	150
<b>Code Main ports</b>					
<b>B</b> BSP threads	x	x	x	x	-
<b>R</b> With anti-cavitation valve; clockwise rot'n <sup>2)</sup>	-	x	x	x	-
<b>L</b> With anti-cavitation valve; counter clockw. <sup>2)</sup>	-	x	x	x	-
<b>U</b> SAE, UN threads	(x)	(x)	-	(x)	-
<b>F</b> SAE 6000 psi flange	-	-	-	-	x

Frame size	5	10	14	19	150
<b>Code Shaft seal</b>					
<b>N</b> NBR <sup>3)</sup> , low pressure	x	x	-	x	x
<b>H</b> NBR <sup>3)</sup> , high pressure	x	x	-	x	x
<b>E</b> FPM <sup>4)</sup> , low pressure, high temperature	x	x	x	x	x
<b>V</b> FPM <sup>4)</sup> , high pressure, high temperature	-	x	x	x	-

Frame size	5	10	14	19	150
<b>Code Mounting flange</b>					
<b>C</b> CETOP flange	x	x	x	x	x
<b>W</b> Saw motor flange	-	x	x	x	-

Frame size	5	10	14	19	150
<b>Code Option</b>					
<b>S</b> With speed sensor	-	-	x	x	-
<b>P</b> Prepared for speed sensor	-	-	x	x	-

- x: Available      (x): Optional      -: Not available
- 1) Internal drain
- 2) BSP threads
- 3) NBR - Nitrile rubber
- 4) FPM - Fluor rubber

**Ordering codes**

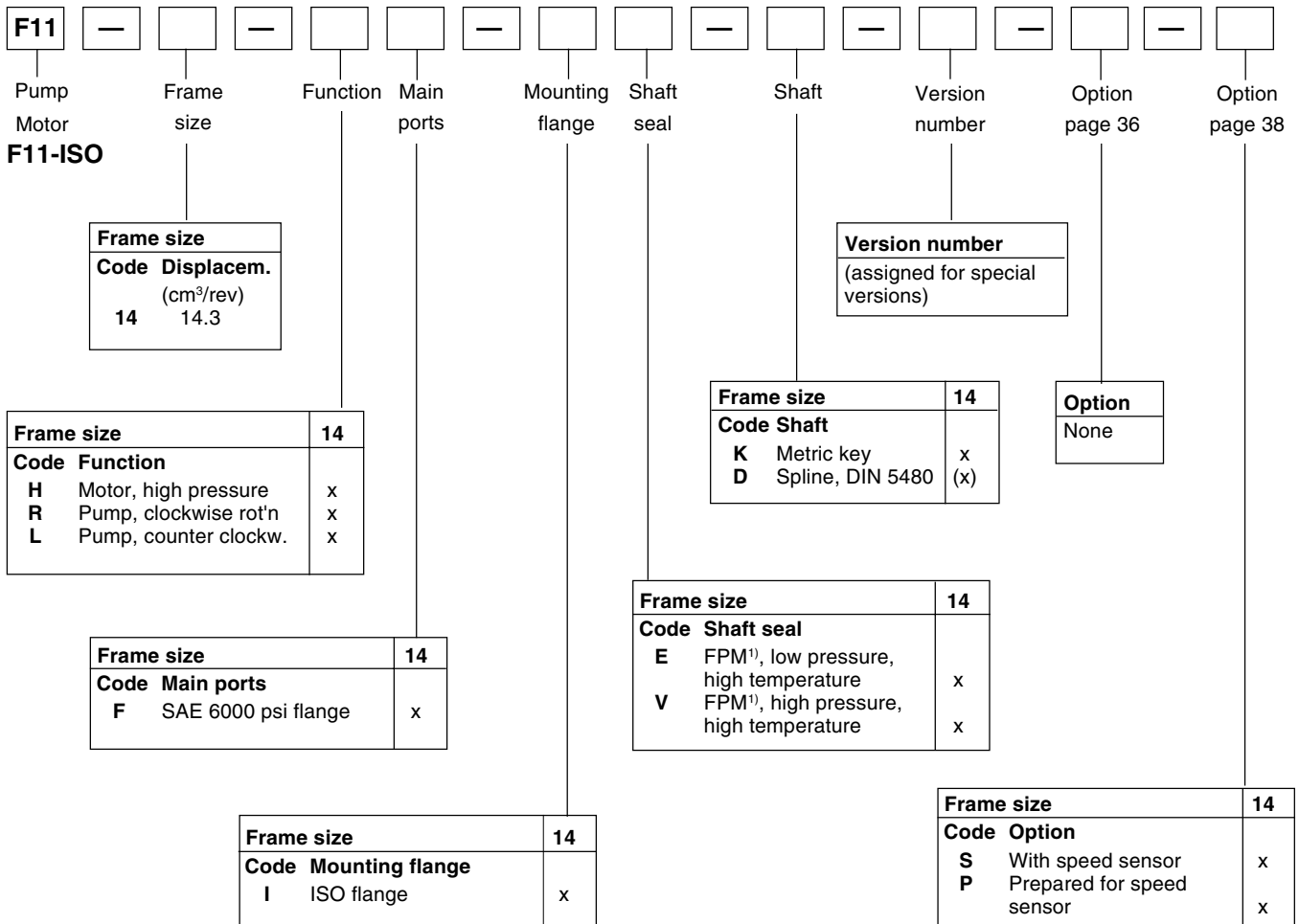

x: Available      (x): Optional      — : Not available  
1) FPM - Fluor rubber



**Ordering codes**

**Series F11/F12**

<b>F11</b>	<b>—</b>		<b>—</b>			<b>—</b>			<b>—</b>		<b>—</b>		<b>—</b>	
Pump Motor	Frame size	Function	Main ports	Mounting flange	Shaft seal	Shaft	Version number	Option page 36	Option page 38					

**F11-SAE**

Frame size		14	19	150	250
<b>Code</b>	<b>Displacem.</b> (cm <sup>3</sup> /rev)				
<b>14</b>	14.3				
<b>19</b>	19.0				
<b>150</b>	150.0				
<b>250</b>	242.0				

Code	Function	14	19	150	250
<b>M</b>	Motor	-	x	x	-
<b>H</b>	Motor, high pressure	x	x	x	-
<b>Q</b>	Motor, silent	-	(x)	(x)	x
<b>J</b>	Motor, clockwise rot'n <sup>1)</sup>	-	(x)	(x)	-
<b>G</b>	Motor, counter clockw. <sup>1)</sup>	-	(x)	(x)	-
<b>R</b>	Pump clockwise rot'n	x	x	x	x
<b>L</b>	Pump counter clockw.	x	x	x	x

Code	Main ports	14	19	150	250
<b>U</b>	SAE, UN threads	x	x	-	-
<b>B</b>	BSP threads	-	(x)	-	-
<b>F</b>	SAE 6000 psi flange <sup>2)</sup>	-	-	x	x

Code	Mounting flange	14	19	150	250
<b>S</b>	SAE flange	x	x	x	x

Version number		14	19	150	250
<b>Code</b>	<b>Shaft</b>				
<b>T</b>	SAE key	x	x	x	-
<b>S</b>	SAE spline	(x)	(x)	(x)	(x)
<b>K</b>	Metric key	-	-	-	x
<b>F</b>	SAE spline	-	-	-	(x)

Code	Shaft seal	14	19	150	250
<b>N</b>	NBR <sup>3)</sup> , low pressure	-	x	x	x
<b>H</b>	NBR <sup>3)</sup> , high pressure	-	x	x	x
<b>E</b>	FPM <sup>4)</sup> , low pressure, high temperature	x	x	x	x
<b>V</b>	FPM <sup>4)</sup> , high pressure, high temperature	x	x	-	-

  

Code	Option	14	19	150	250
<b>S</b>	With speed sensor	x	x	-	-
<b>P</b>	Prepared for speed sensor	x	x	-	-

Option					
	None				

- x: Available      (x): Optional      -: Not available
- 1) Internal drain
  - 2) Metric thread
  - 3) NBR - Nitrile rubber
  - 4) FPM - Fluor rubber

**Ordering codes**

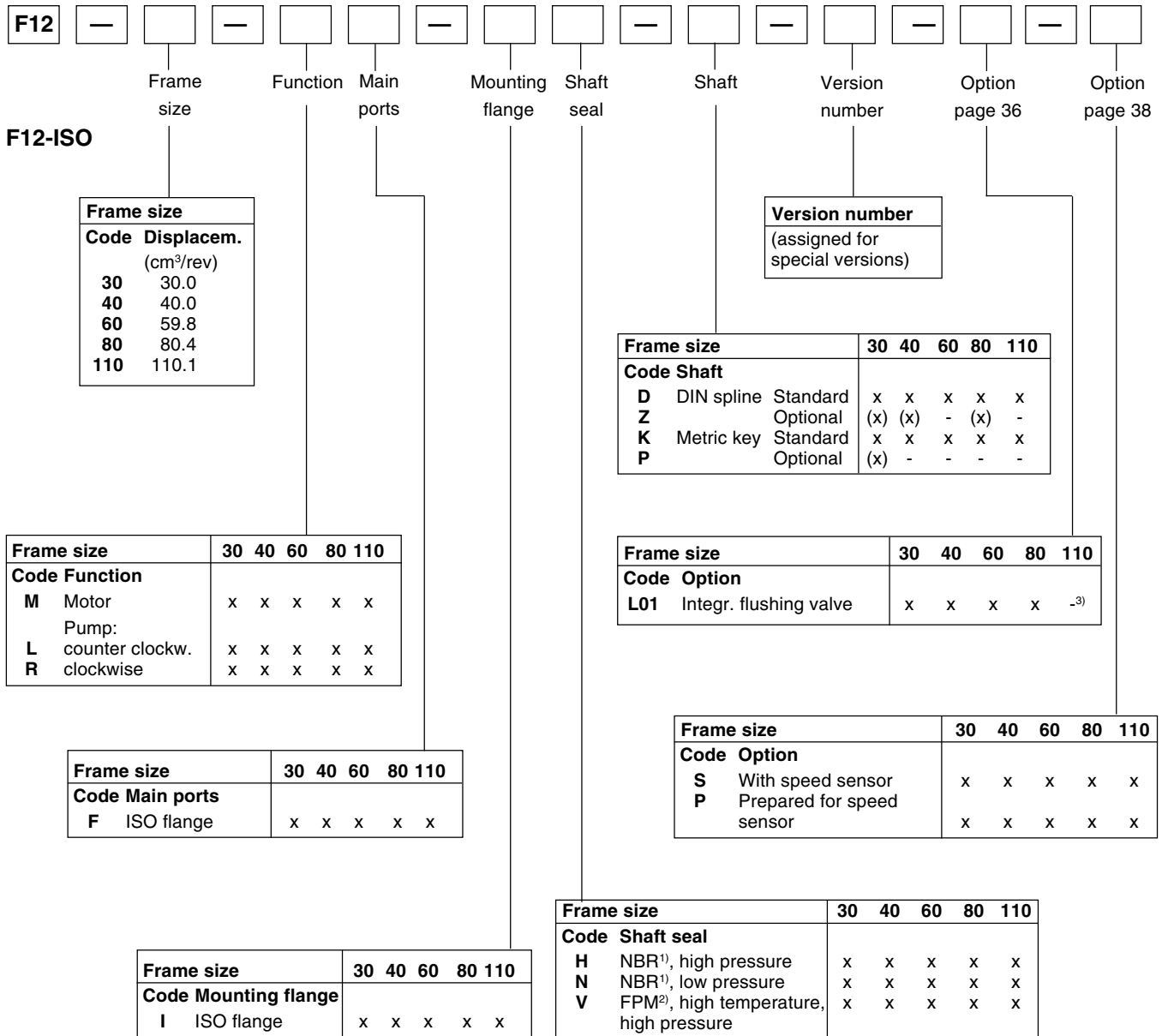

x: Available (x): Optional - : Not available

1) NBR - Nitrile rubber

2) FPM - Fluor rubber

3) F12-110: Accessory valve block (page 36)

**Ordering codes**

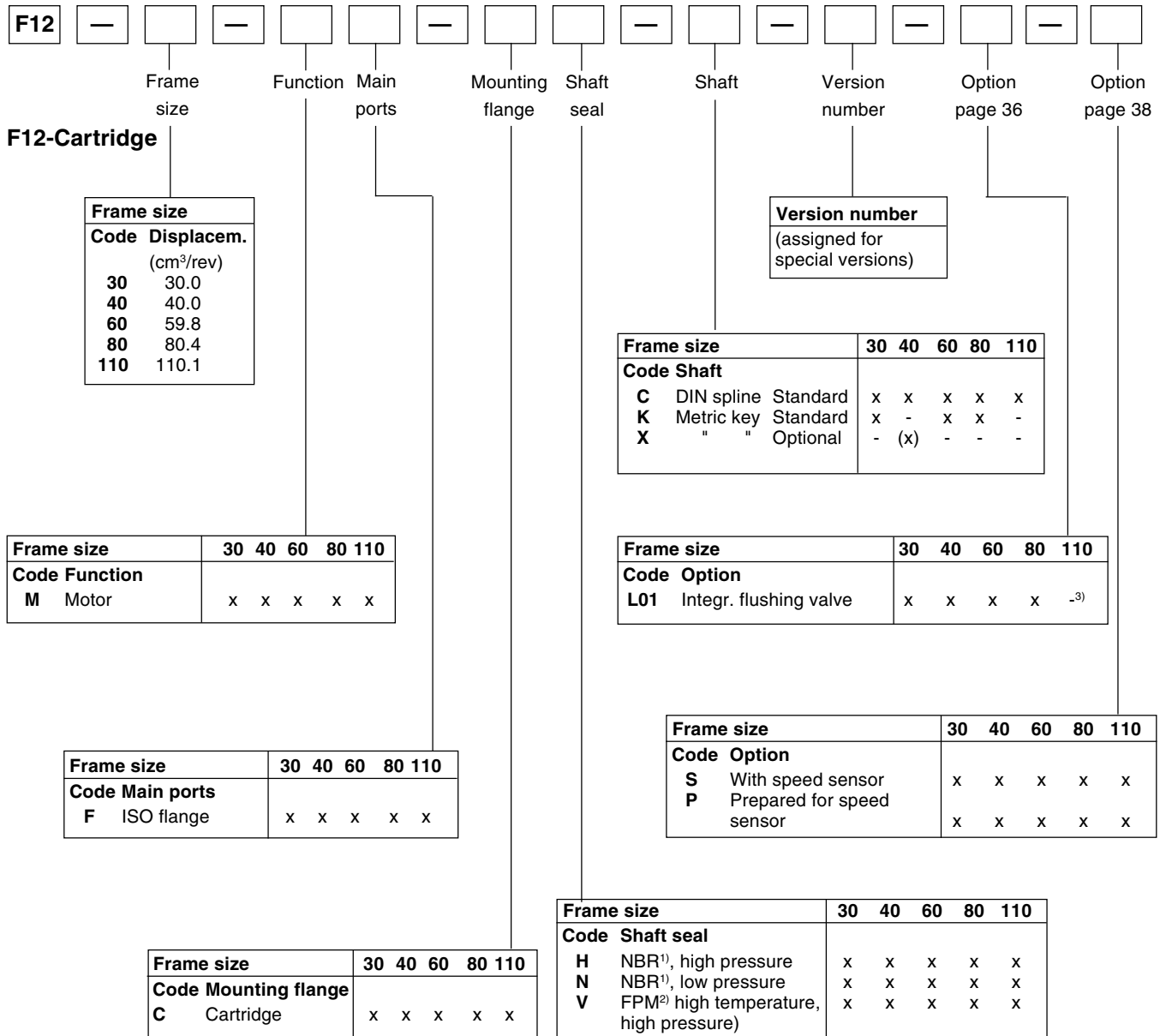

x: Available      (x): Optional      - : Not available  
 1) NBR - Nitrile rubber  
 2) FPM - Fluor rubber  
 3) F12-110: Accessory valve block (page 36)

Ordering codes

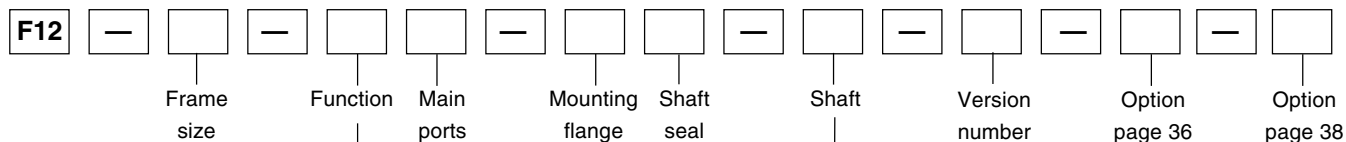

F12-SAE

Frame size	
Code	Displacem. (cm <sup>3</sup> /rev)
30	30.0
40	40.0
60	59.8
80	80.4
110	110.1

Version number
(assigned for special versions)

Frame size		30	40	60	80	110
<b>Code Shaft</b>						
S	SAE spline Standard	x	x	x	x	x
U	" " Optional	-	-	-	(x)	-
T	SAE key Standard	x	x	x	x	x

Frame size		30	40	60	80	110
<b>Code Function</b>						
M	Motor	x	x	x	x	x
Pump:						
L	counter clockw.	x	x	x	x	x
R	clockwise	x	x	x	x	x

Frame size		30	40	60	80	110
<b>Code Option</b>						
L01	Integr. flushing valve	x	x	x	x	- <sup>3)</sup>

Frame size		30	40	60	80	110
<b>Code Main ports</b>						
S	SAE flange	x	x	x	x	x
U	SAE, UN threads	(x)	(x)	(x)	-	(x)

Frame size		30	40	60	80	110
<b>Code Option</b>						
S	With speed sensor	x	x	x	x	x
P	Prepared for speed sensor	x	x	x	x	x

Frame size		30	40	60	80	110
<b>Code Mounting flange</b>						
S	SAE 4 bolt	x	x	x	x	x
T	SAE 2 bolt	x	x	x	-	-

Frame size		30	40	60	80	110
<b>Code Shaft seal</b>						
H	NBR <sup>1)</sup> , high pressure	x	x	x	x	x
N	NBR <sup>1)</sup> , low pressure	x	x	x	x	x
V	FPM <sup>2)</sup> , high temperature, high pressure	x	x	x	x	x

x: Available (x): Optional - : Not available

1) NBR - Nitrile rubber

2) FPM - Fluor rubber

3) F12-110: Accessory valve block (page 36)

**Preferred versions F11/F12****F11**

<b>Ordering Codes</b>	<b>Part number</b>
F11-005-MB-CN-K	3703665
F11-005-MB-CH-K	3707249
F11-005-HU-CH-K	3707308
F11-010-MB-CN-K	3703603
F11-010-MB-CH-K	3706030
F11-010-HU-CH-K	3707310
F11-014-HB-CE-K	3783201
F11-014-HB-CV-K	3782830
F11-019-MB-CN-K	3703516
F11-019-MB-CH-K	3707893
F11-150-MF-CN-K	3703468
F11-150-MF-CH-K	3707008
F11-150-HF-SH-S	3707325
F11-250-QF-SH-F	3706440
F11-250-QF-SH-K	3795858

**F12**

<b>Ordering Codes</b>	<b>Part number</b>
F12-30-MF-IH-D	3799843
F12-30-MF-IH-K	3799844
F12-30-MS-SH-S	3799851
F12-30-MS-TH-S	3799616
F12-40-MF-IH-D	3799525
F12-40-MF-IH-K	3799526
F12-40-MS-SH-S	3799532
F12-40-MS-SH-T	3799533
F12-40-MS-TH-S	3799617
F12-60-MF-IH-D	3799988
F12-60-MF-IH-K	3799989
F12-60-MS-SH-S	3799998
F12-60-MS-TH-S	3799618
F12-80-MF-IH-D	3780767
F12-80-MF-IH-K	3780772
F12-80-MS-SH-S	3780783
F12-110-MF-IH-D	3781530
F12-110-MF-IH-K	3781534
F12-110-MS-SH-S	3781542

## Bearing life

### General information

Bearing life can be calculated for that part of the load/ life curve (shown below) that is designated 'Bearing fatigue'. 'Rotating group fatigue and wear' and 'Other' caused by material fatigue, fluid contamination, etc. should also be taken into consideration when estimating the service life of a motor/pump in a specific application.

Bearing life calculations are mainly used when comparing different frame sizes. Bearing life, designated  $B_{10}$  (or  $L_{10}$ ), is dependent of system pressure, operating speed, external shaft loads, fluid viscosity in the case, and fluid contamination level.

The  $B_{10}$  value means that 90% of the bearings survive, at a minimum, the number of hours calculated. Statistically, 50% of the bearings will survive at least five times the  $B_{10}$  life.

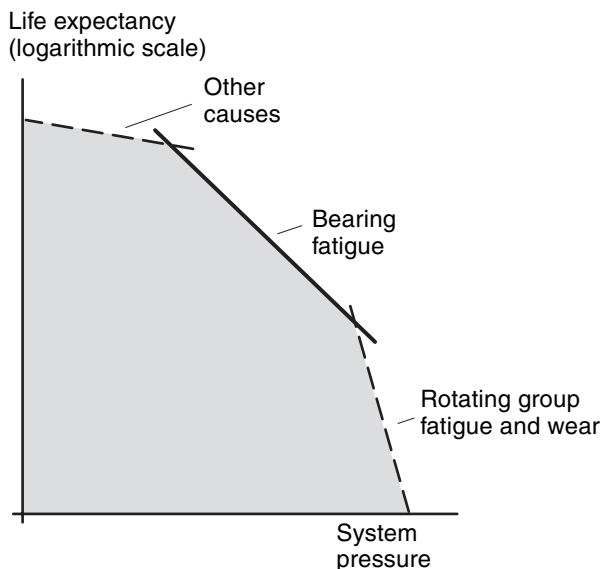

Hydraulic unit life versus system pressure.

### Bearing life calculation

An application is usually governed by a certain duty or work cycle where pressure and speed vary with time during the cycle.

In addition, bearing life depends on external shaft forces, fluid viscosity in the case and fluid contamination.

Parker Hannifin (Mobile Controls Division) has a computer program for calculating bearing life and will assist in determining F11 or F12 motor/pump life in a specific application.

### Required information

When requesting a bearing life calculation from Parker Hannifin (Mobile Controls Division), the following information (where applicable) should be provided:

- A short presentation of the application
- F11 or F12 size and version
- Duty cycle (pressure and speed versus time at given displacements)
- Low system pressure
- Case fluid viscosity
- Life probability ( $B_{10}$ ,  $B_{20}$ , etc.)
- Operating mode (pump or motor)
- Direction of rotation (L or R)
- External shaft loads
- Fixed or rotating radial load
- Distance between flange and radial load
- Angle of attack ( $\alpha$ ) as defined below

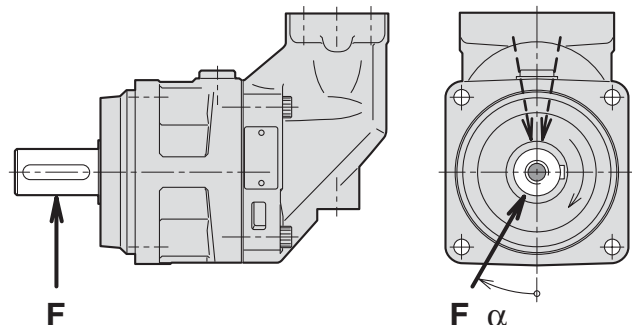

The direction (a) of the radial load is positive in the direction of rotation as shown.

To obtain maximum bearing life, the radial load should, in most cases, be located approximately at  $170^\circ$  (motor; R.H. rot'n) or  $190^\circ$  (pump; R.H rot'n).

**Efficiency**

Because of its high overall efficiency, driving a motor/pump from series F11/F12 requires less fuel or electric power. Also, it allows the use of a small reservoir and heat exchanger, which in turn reduce cost, weight, and installation size.

The diagrams to the right shows volumetric and mechanical efficiencies of an F12-30.

Contact Parker Hannifin for efficiency information on a particular F11/F12 frame size that is being considered.

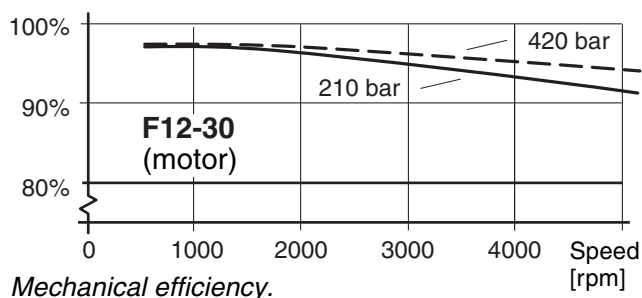
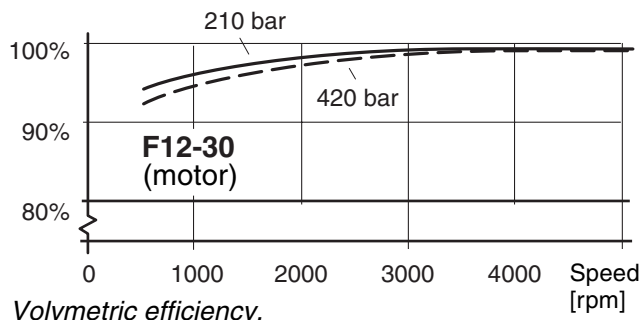

**Noise level**

Series F11/F12 feature low noise levels from low to high speeds and pressures.

As an example, the diagram to the right shows the noise level of an F12-30.

The noise level is measured in a semi-anechoic room, 1 m behind the unit.

The noise level for a particular motor/pump may vary  $\pm 2$  dB(A) compared to what is shown in the diagram.

**NOTE:** Noise information for F11/F12 frame sizes are available from Parker Hannifin.

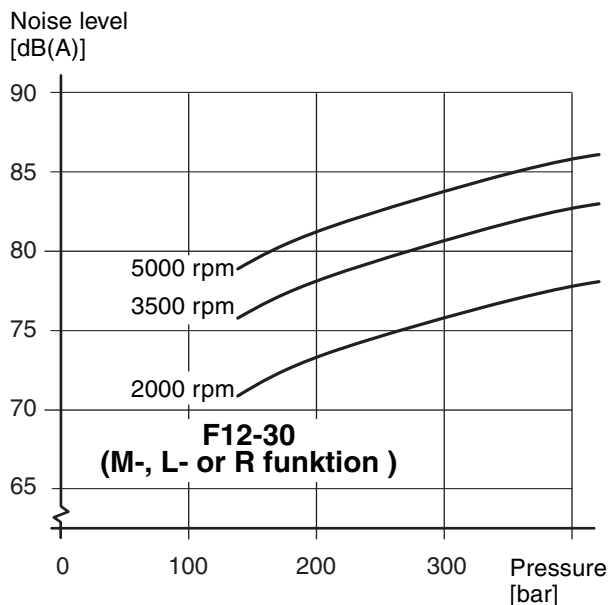

**Selfpriming speed and required inlet pressure**

**Series F11**

In pump applications, the F11 with function **L** (counter clockwise rotation) or **R** (clockwise rotation) is normally used. The **L** and **R** (pump) provide the highest selfpriming speeds (see table) as well as the lowest noise level. The **M** (motor) function can also be used as a pump, in either direction, but at a lower selfpriming speed.

Operating above the selfpriming speed (refer to Diagram 1) requires increased inlet pressure.

As an example, at least 1.0 bar is needed when operating the F11-19-M as a pump at 3500 rpm. An F11 with **H** function, used as a motor (e.g. in a hydrostatic transmission), may sometimes operate as a pump at speeds above the selfpriming speed; this requires additional inlet pressure.

Insufficient inlet pressure can cause pump cavitation resulting in greatly increased pump noise and deteriorating performance.

Function	L or R	M	H
F11-5	4600	3800	3200
F11-10	4200	3100	2700
F11-14	3900	-	3200
F11-19	3500	2400	2100
F11-150	1700	1300	1100
F11-250	1500	950	-

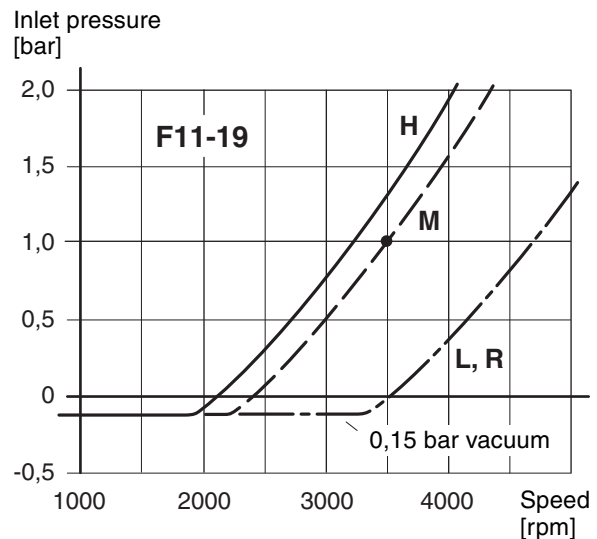
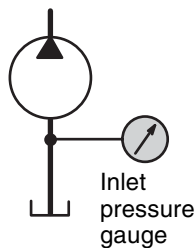

Diagram 1. Min required inlet pressure (F11-19).

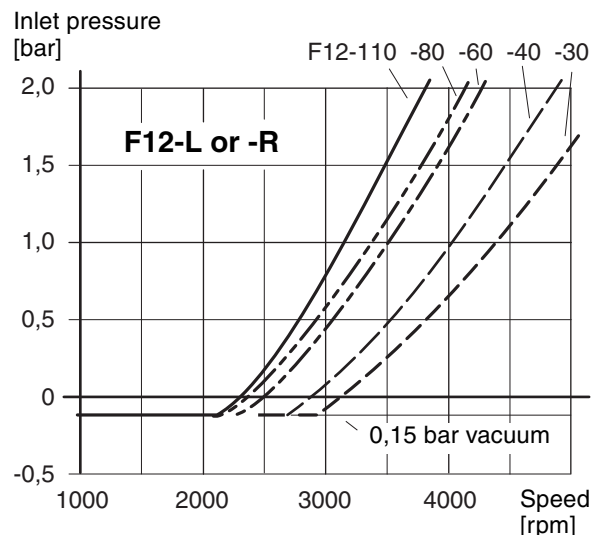

Diagram 2. Min. required pump (F12-L or -R) inlet press.

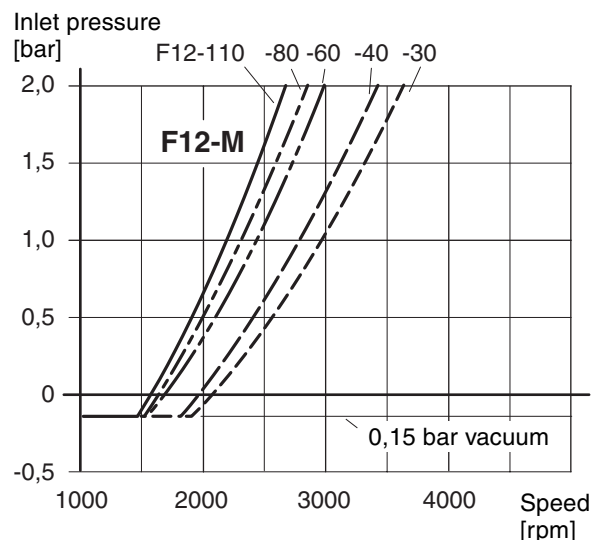

Diagram 3. Min. required motor (F12-M) inlet pressure.

**Series F12**

When operating the F12 as a pump (with **L** or **R** valve plate) above the selfpriming speed, the inlet must be pressurized. Increased noise and deteriorating performance may otherwise be experienced.

Diagrams 2 and 3 show required pump inlet pressure vs. shaft speed.

The F12 motor (type **M** valve plate) sometimes operates as a pump e.g. when used in a propel transmission and the vehicle is going downhill.

Minimum required inlet pressure versus shaft speed is shown in the diagrams.

**NOTE:** Diagrams 1, 2 and 3 are valid at sea level.



**F11-5**  
 (CETOP versions)

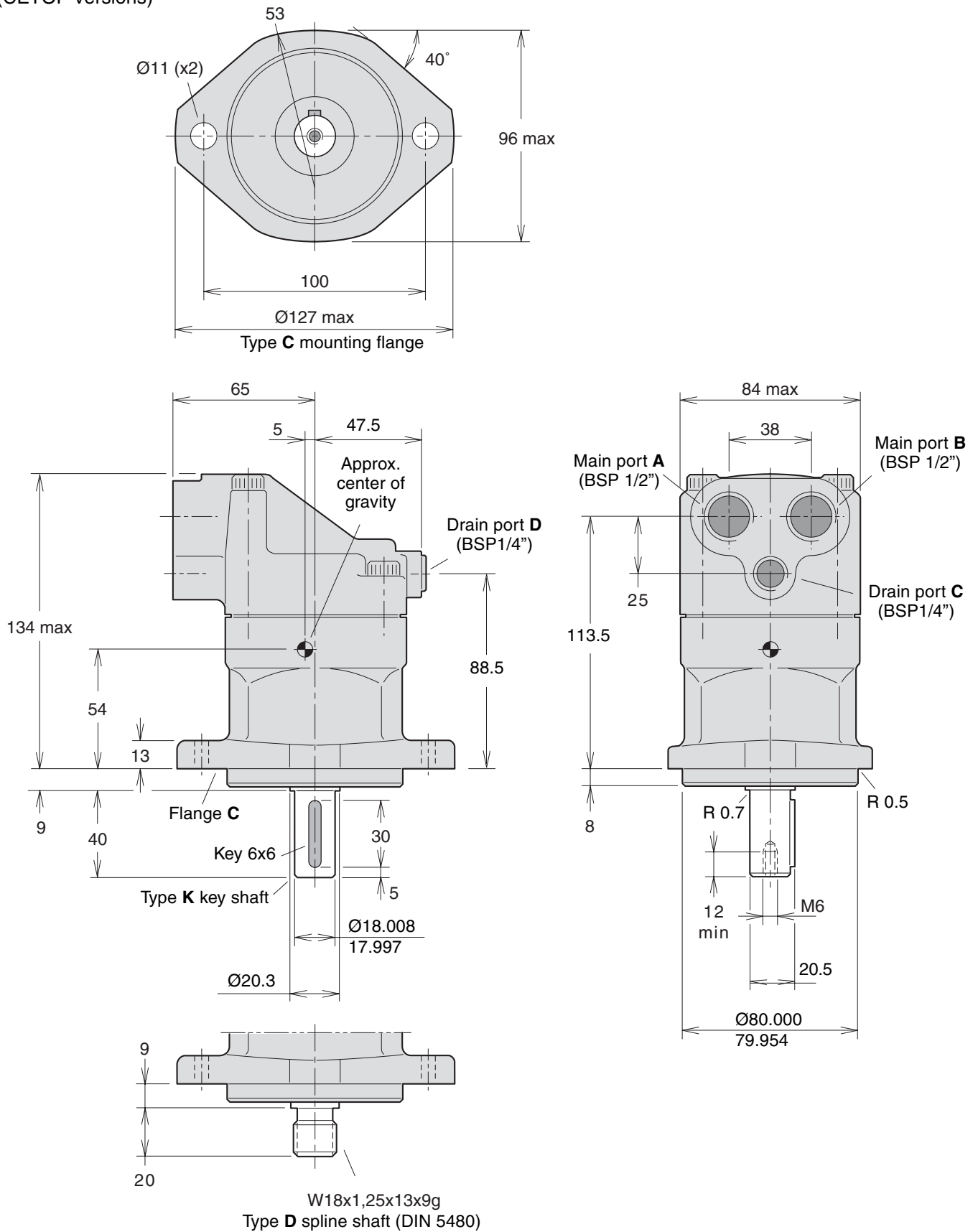

**F11-10**

(CETOP versions)

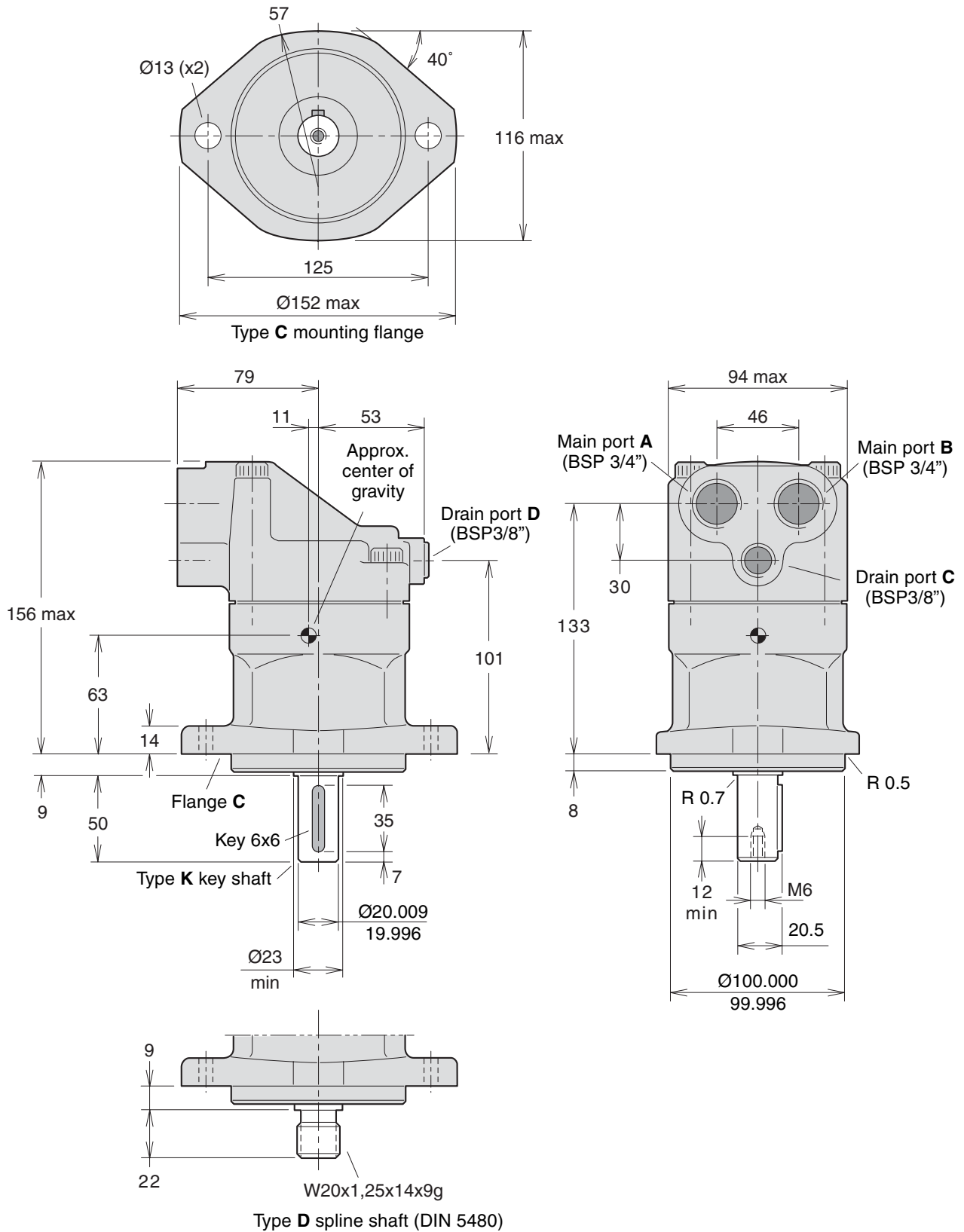

**F11-14**  
 (CETOP versions)

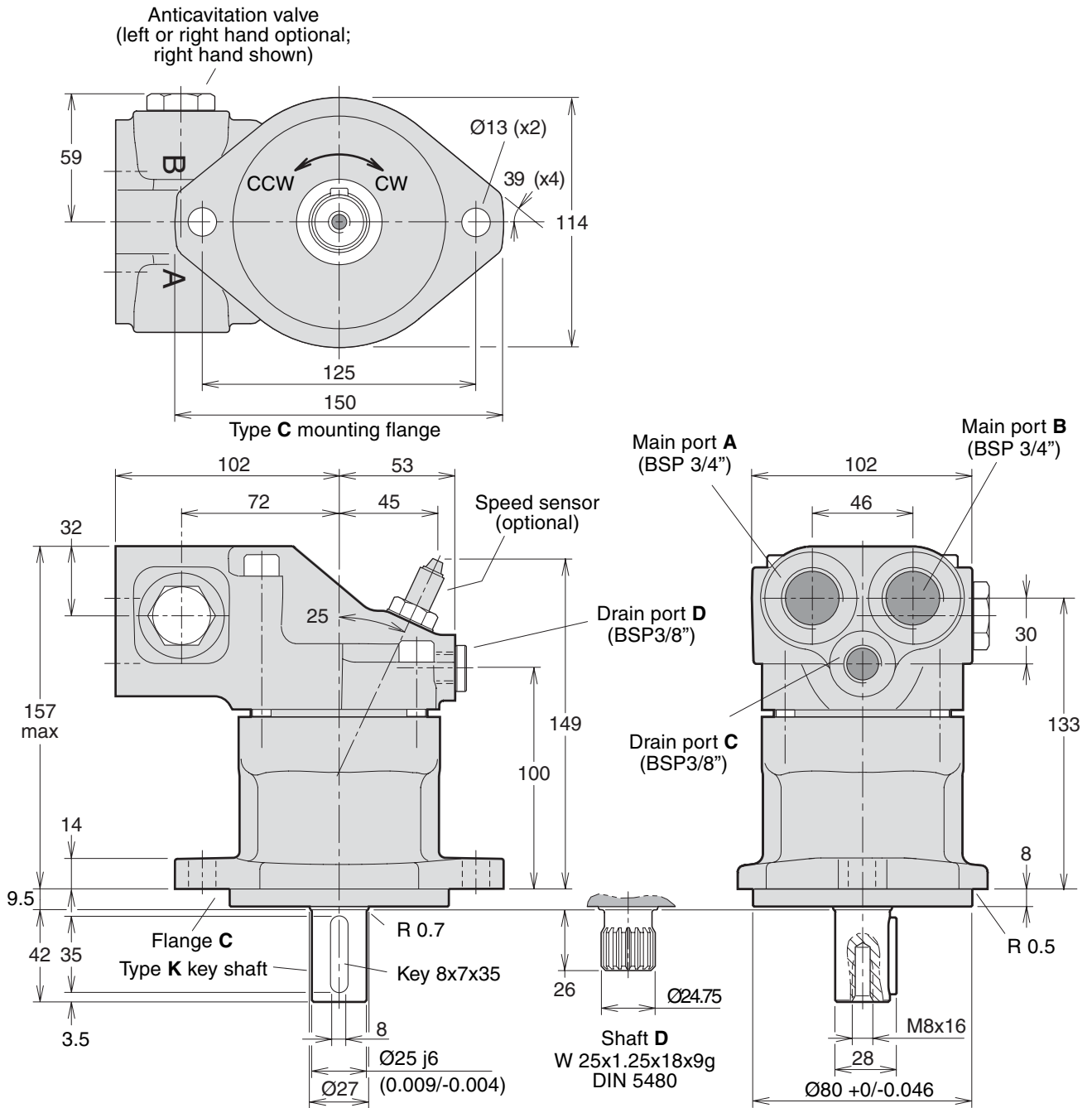

**F11-19**

(CETOP version)

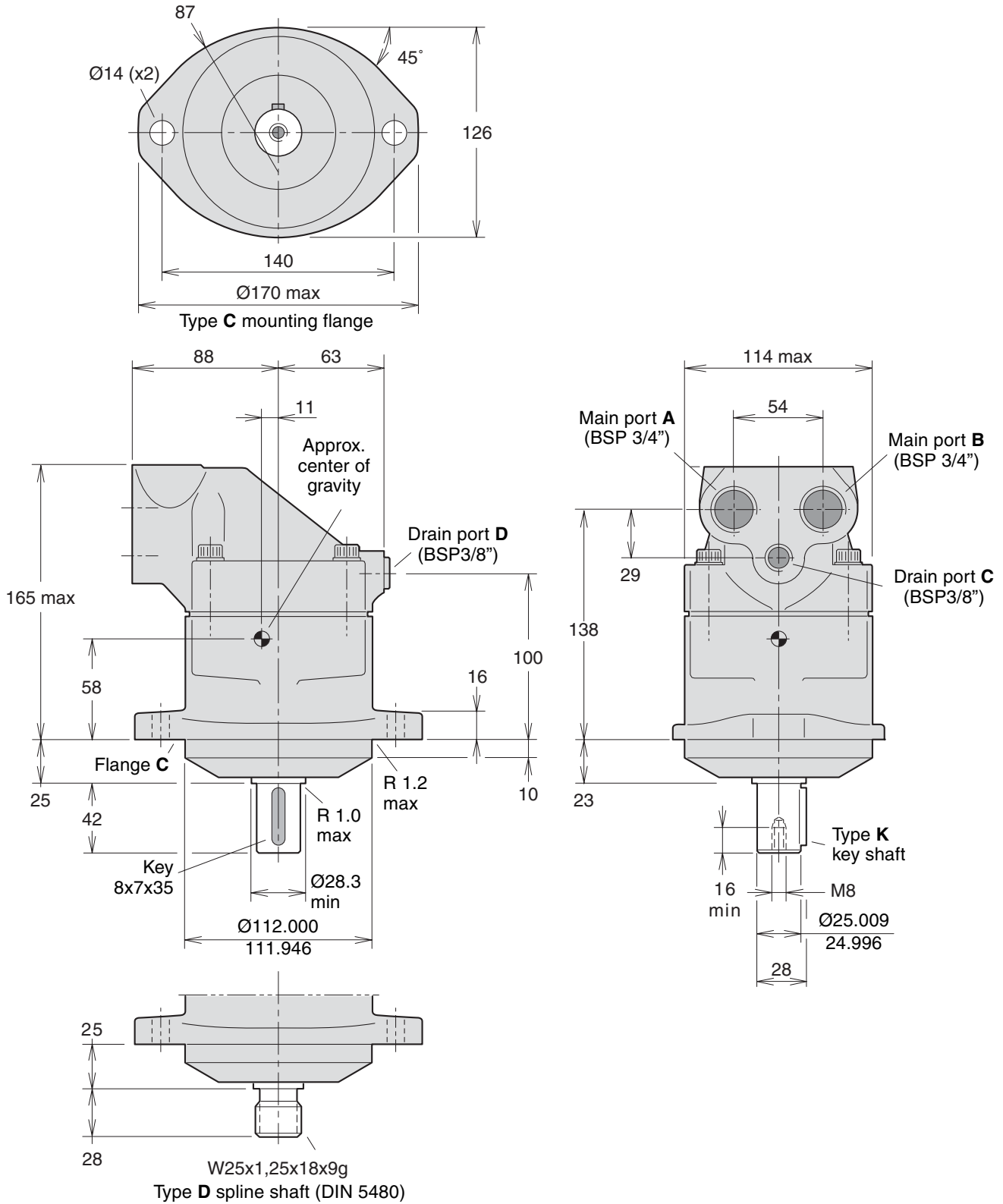

**F11-14**  
 (ISO versions)

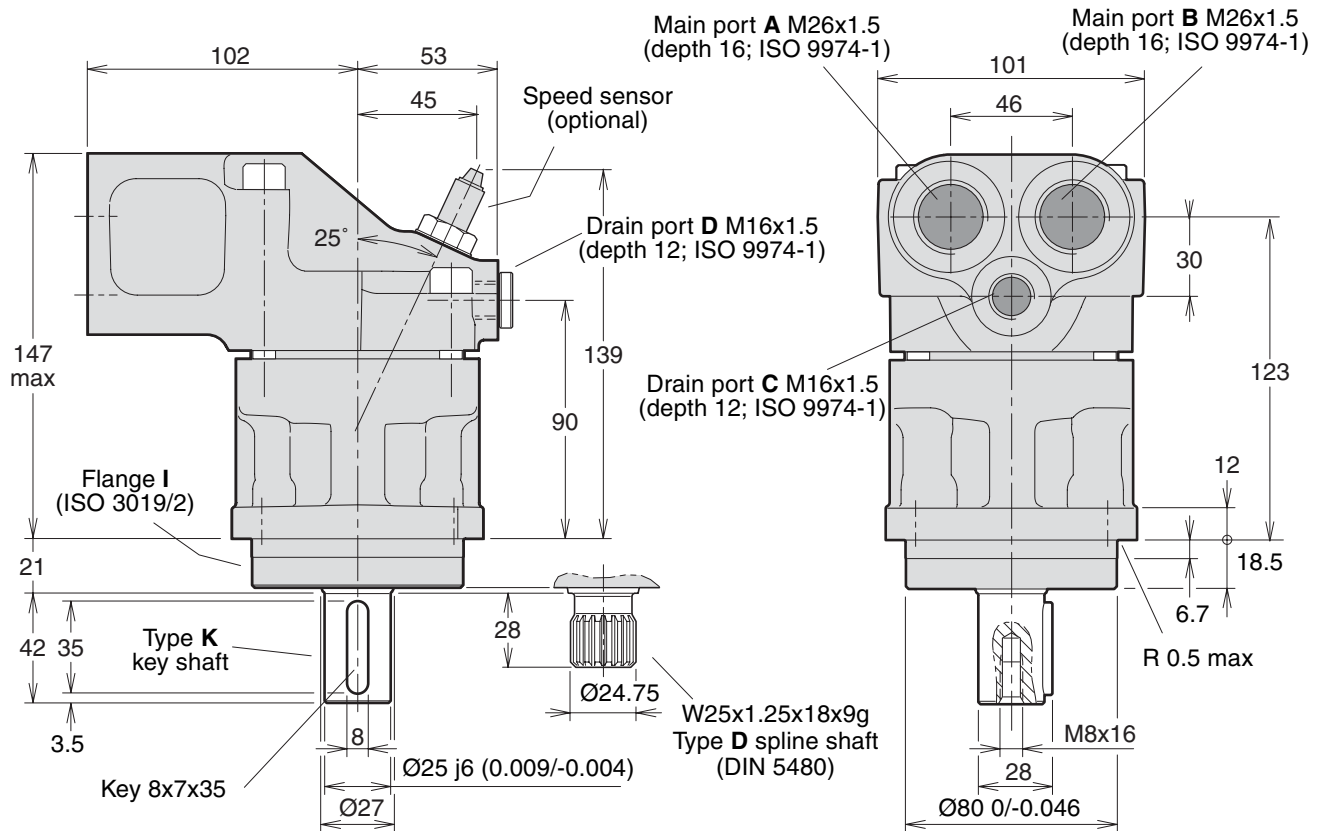
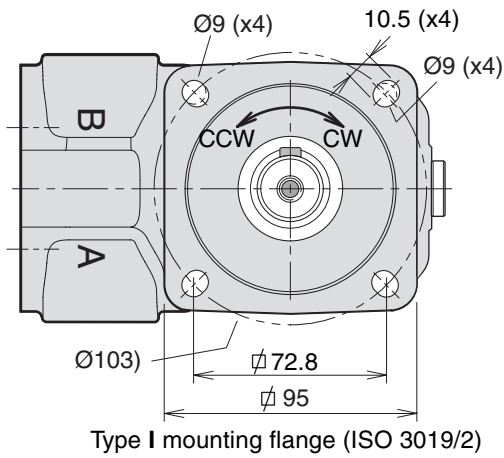

F11-14

(SAE versions)

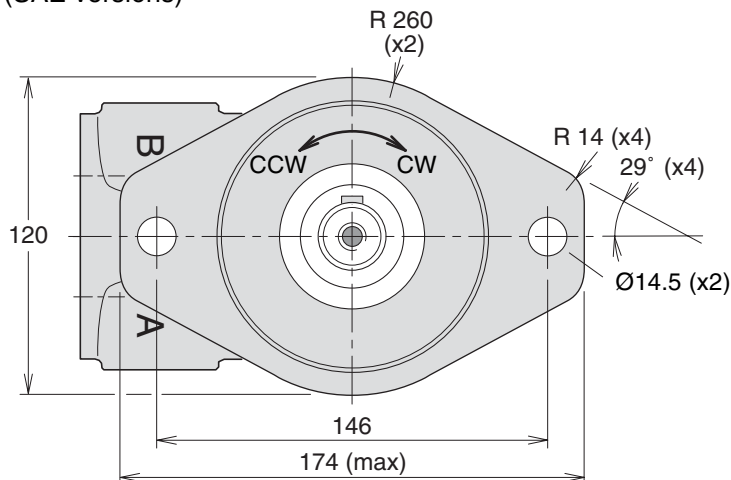

Type S mounting flange SAE 'B' ( SAE J744c)

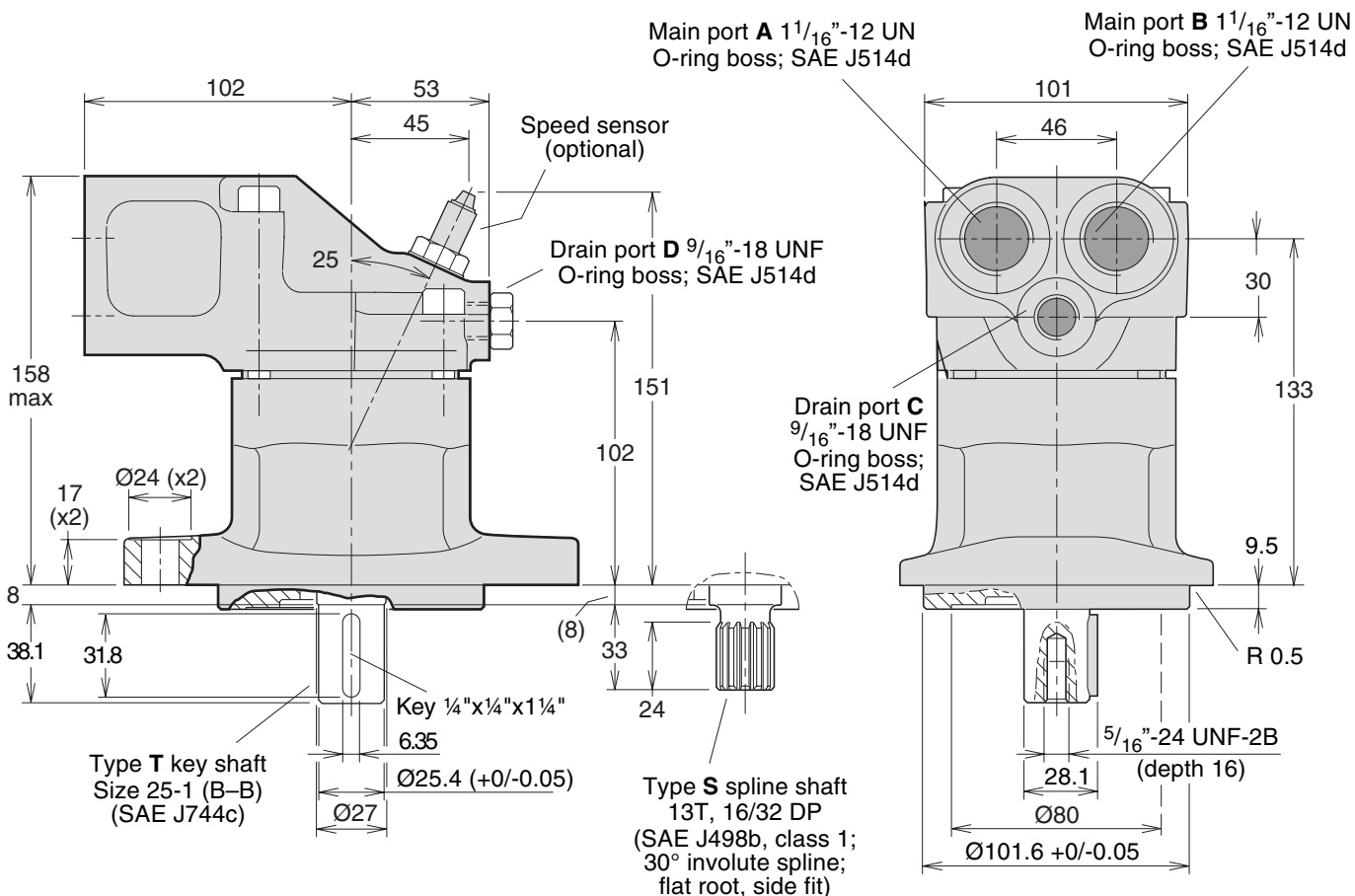

Main port A  $11/16$ "-12 UN O-ring boss; SAE J514d

Main port B  $11/16$ "-12 UN O-ring boss; SAE J514d

Speed sensor (optional)

Drain port D  $9/16$ "-18 UNF O-ring boss; SAE J514d

Drain port C  $9/16$ "-18 UNF O-ring boss; SAE J514d

Type T key shaft Size 25-1 (B-B) (SAE J744c)

Type S spline shaft 13T, 16/32 DP (SAE J498b, class 1; 30° involute spline; flat root, side fit)

**F11-19**

(SAE version)

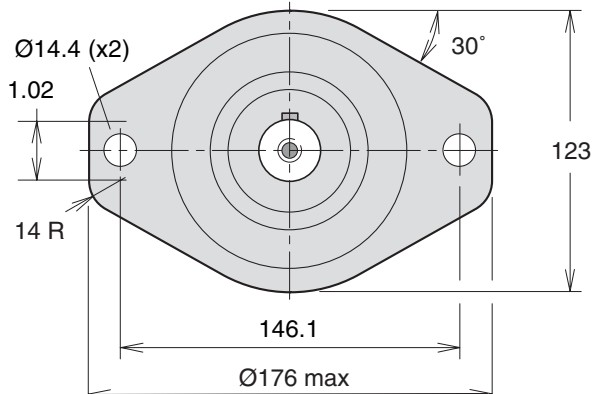

Type S mounting flange SAE 'B' (SAE J744c)

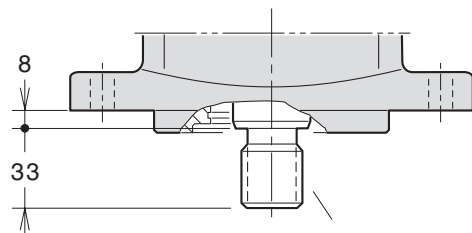
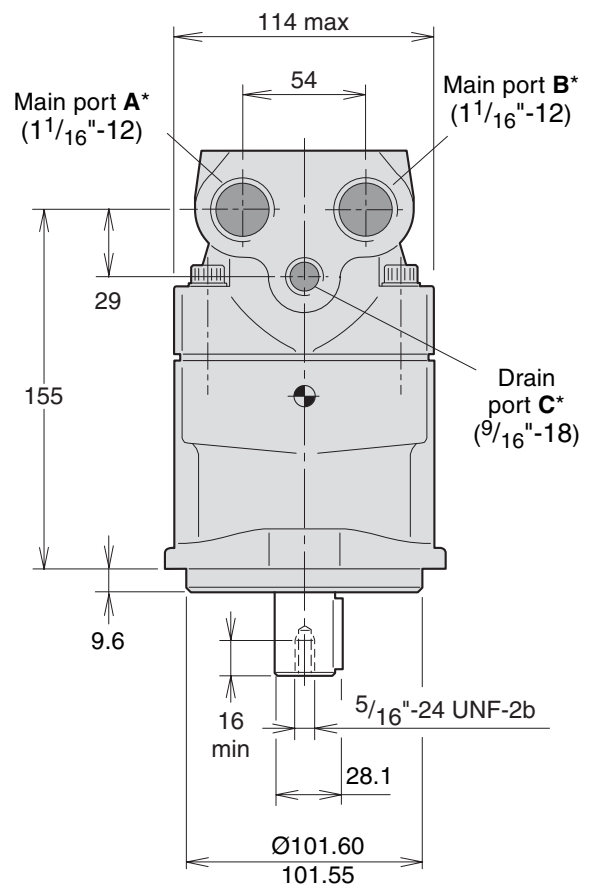
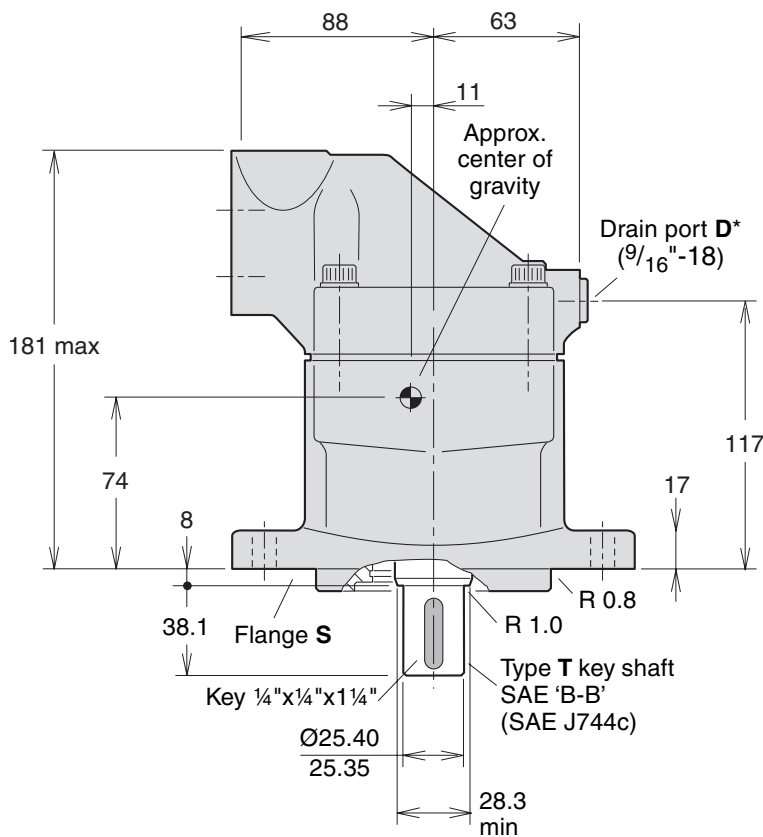

SAE 'B' (13T, 16/32 DP);  
 Type S spline shaft (SAE J498b)

\* O-ring ports according to SAE J514d

**F12-30, -40, -60, -80 and -110**  
 (ISO versions)

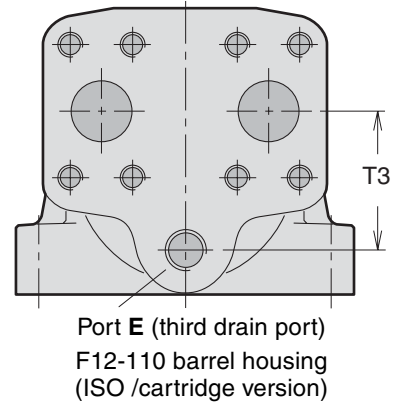
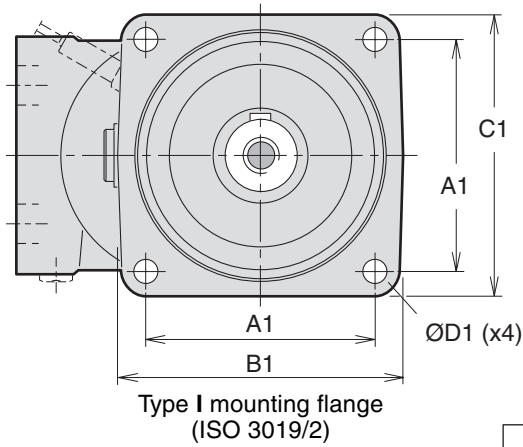

F12-80 shown

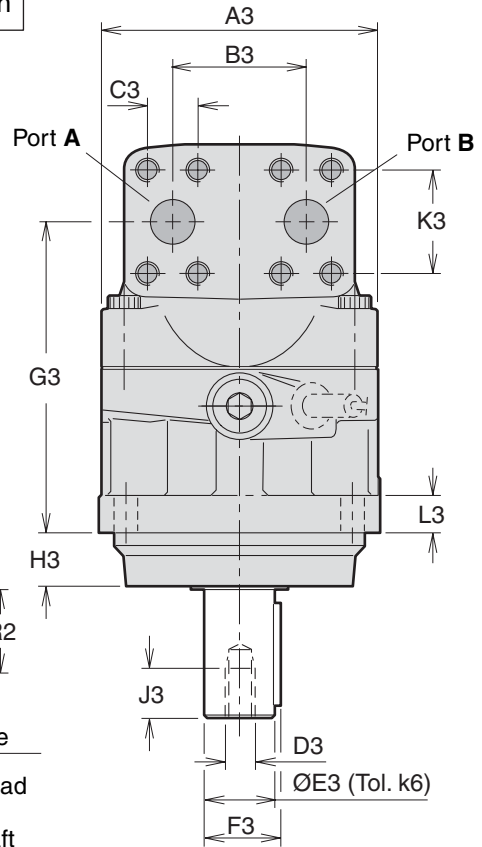
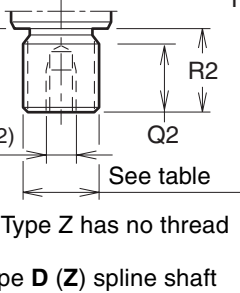
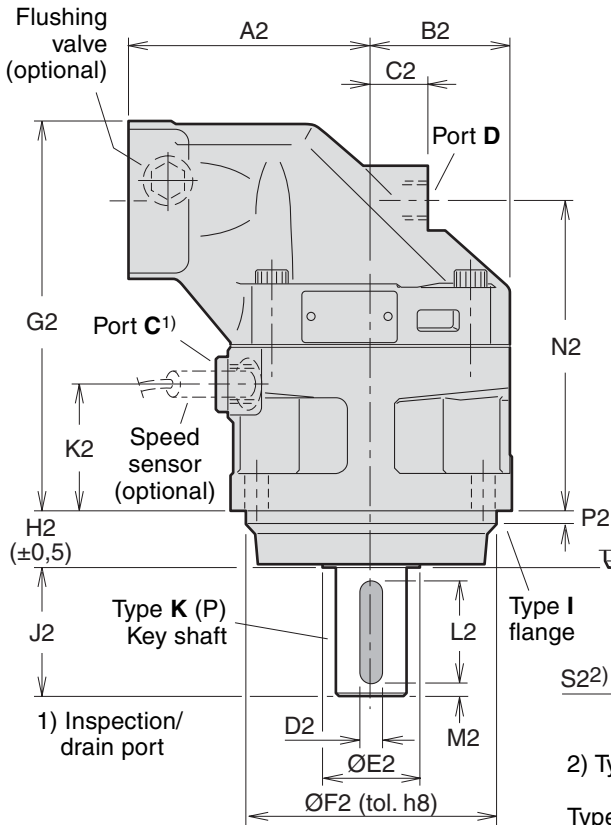

2) Type Z has no thread  
 Type D (Z) spline shaft



Dim.	F12-30	F12-40	F12-60	F12-80	F12-110	Ports	F12-30	F12-40	F12-60	F12-80	F12-110
A1	88.4	113.2	113.2	127.2	141.4	A, B size	3/4"	3/4"	3/4"	1"	1 1/4"
B1	118	146	146	158	180	Screw thread <sup>1)</sup>	M10 x20	M10 x20	M10 x20	M12 x20	M14 x26
C1	118	142	144	155	180	C thread <sup>2)</sup>	M22 x1.5	M22 x1.5	M22 x1.5	M22 x1.5	M22 x1.5
D1	11	13.5	13.5	13.5	18	D thread <sup>2)</sup>	M18 x1.5	M18 x1.5	M22 x1.5	M22 x1.5	M22 x1.5
A2	100	110	125	135	145	E thread	-	-	-	-	M22 x1.5
B2	59	65	70	78	85	A, B: ISO 6162    1) Metric thread x depth in mm 2) Metric thread x pitch in mm.					
C2	25	26	22	32	38	<b>Spline shaft (DIN 5480)</b>					
D2	8	8	10	12	14	Type D (standard)		Type Z (optional)			
E2	33	42	42	52	58	F12-30	W30x2x14x9g	W25x1.25x18x9g			
F2	100	125	125	140	160	-40	W32x2x14x9g	W30x2x14x9g			
G2	172	173	190	216	231	-60	W35x2x16x9g	W32x2x14x9g			
H2	25.5	32.5	32.5	32.5	40.5	-80	W40x2x18x9g	W35x2x16x9g			
J2 <sup>1)</sup>	50	60	60	70	82	-110	W45x2x21x9g	-			
J2 <sup>2)</sup>	50	-	-	-	-	<b>Key shaft</b>					
K2	55	52	54	70.5	66.5	Type K (standard)		Type P (optional)			
L2	40	50	50	56	70	F12-30	Ø30	Ø25			
M2	5	5	5	7	6	-40	Ø30	-			
N2	136.5	137	154	172.5	179	-60	Ø35	-			
P2	8	8	8	8	8	-80	Ø40	-			
Q2	28	28	33	36	41	-110	Ø45	-			
R2 <sup>3)</sup>	35	35	41	45	50	= Max 350 bar operating pressure					
R2 <sup>4)</sup>	43	35	35	41	-						
S2 <sup>3)</sup>	M12 x24	M12 x24	M12 x28	M16 x36	M16 x36						
S2 <sup>4)</sup>	-	M12 x24	-	M12 x28	-						
A3	122	134	144	155	170						
B3	66	66	66	75	83						
C3	23.8	23.8	23.8	27.8	31.8						
D3	M12	M12	M12	M16	M16						
E3	30	30	35	40	45						
F3	33	33	38	43	49						
G3	136.5	137	154	172.5	179						
H3	23.5	30.5	30.5	30.5	38.5						
J3	24	24	28	36	36						
K3	50.8	50.8	50.8	57.2	66.7						
L3	18	20	20	20	22						
T3	-	-	-	-	68						

1) Key shaft type K    3) Spline shaft type D  
2) Key shaft type P    4) Spline shaft type Z

**F12-30, -40, -60, -80 and -110**  
 (Cartridge versions)

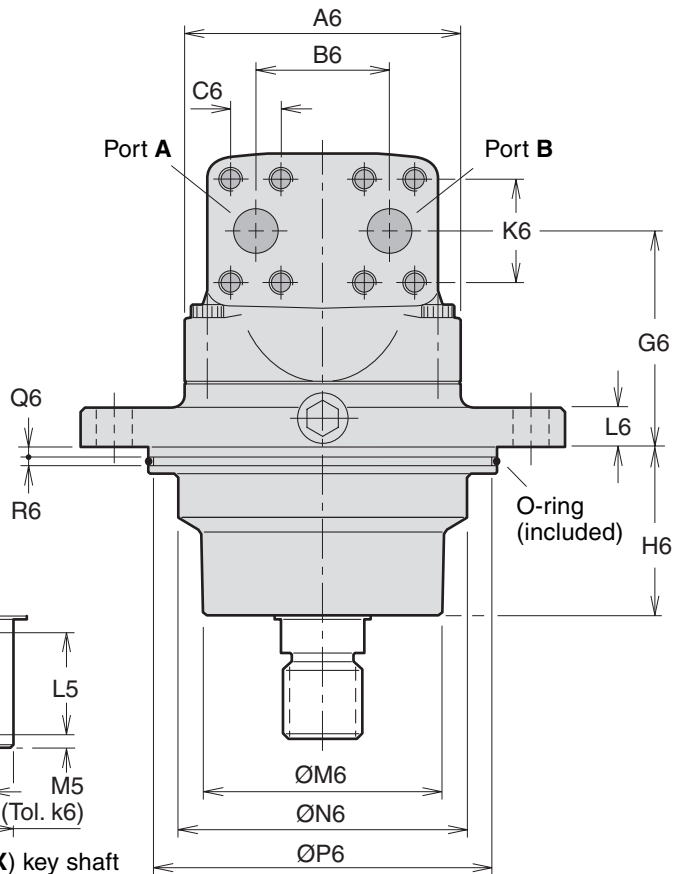
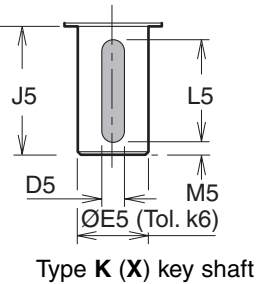
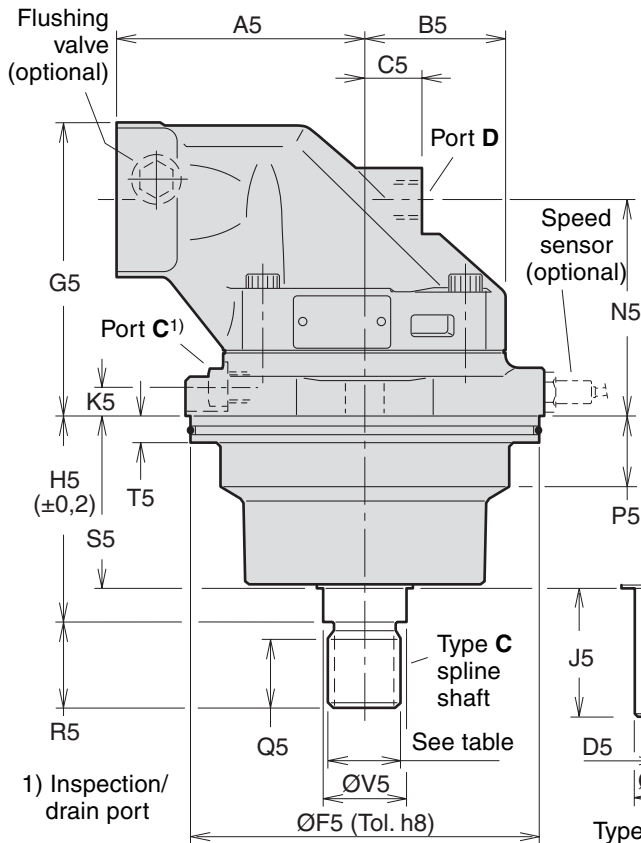
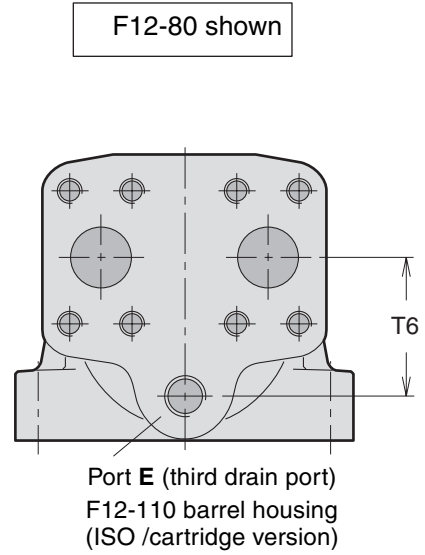
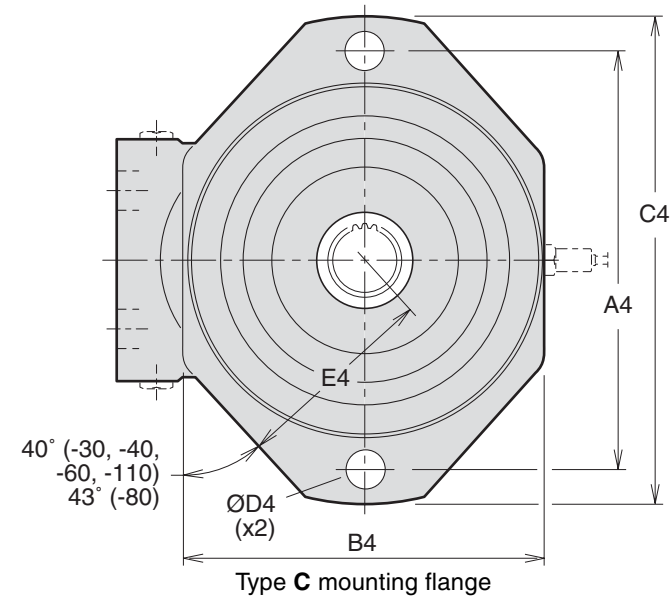

Dim.	F12-30	F12-40	F12-60	F12-80	F12-110	Ports	F12-30	F12-40	F12-60	F12-80	F12-110
A4	160	200	200	224	250	A, B size	3/4"	3/4"	3/4"	1"	1 1/4"
B4	140	164	164	196	206	Screw thread	M10 x20	M10 x20	M10 x20	M12 x22	M14 x26
C4	188	235	235	260	286	C thread	M14 x1.5	M14 x1.5	M14 x1.5	M14 x1.5	M14 x1.5
D4	14	18	18	22	22	D, E thread	M18 x1.5	M18 x1.5	M22 x1.5	M22 x1.5	M22 x1.5
E4	77	95	95	110	116						
A5	100	110	125	135	145						
B5	59	65	70	77.5	85						
C5	25	26	22	32	38						
D5	8	8 <sup>1)</sup> 10 <sup>2)</sup>	10	12	14						
E5	30	30 <sup>1)</sup> 35 <sup>2)</sup>	35	40	45						
F5	135	160	160	190	200						
G5	127	133	146	157	175						
H5	89	92.3	92.3	110.5	122.8						
J5	50	60	60	70	-						
K5	14	16	15	15	15						
L5	40	50	50	56	-						
M5	5	5	5	7	-						
N5	91	97	110	114	123						
P5	22	30	31	40	40						
Q5	28	28	28	37	37						
R5	35	35	35	45	45						
S5	70.5	72	76	91	95.7						
T5	15	15	15	15	15						
V5	32	35	35	45	45						
A6	122	134	144	155	170						
B6	66	66	66	75	83						
C6	23.8	23.8	23.8	27.8	31.8						
G6	91.5	97	110	114	123						
H6	69.5	71	74	89.5	93.7						
K6	50.8	50.8	50.8	57.2	66.7						
L6	16	18	18	20	20						
M6	92	115	115	130	140						
N6	110	127	135	154	160						
P6	128.2	153.2	153.2	183.2	193.2						
Q6	5	5	5	5	5						
R6	5	5	5	5	5						
T6	-	-	-	-	68						

A, B: ISO 6162

**Spline shaft (DIN 5480)**

Type C (standard)

F12-30	W30x2x14x9g
-40	W30x2x14x9g
-60	W30x2x14x9g
-80	W40x2x18x9g
-110	W40x2x18x9g

**Key shaft**

Type K (std)    Type X (opt.)

F12-30	Ø30	-
-40	-	Ø35
-60	Ø35	-
-80	Ø40	-

**O-ring dimensions**

F12-30	127x4
-40	150x4
-60	150x4
-80	180x4
-110	190x4

1) Key shaft type K

2) Key shaft type X (opt.).

**F12-30, -40, -60, -80 and -110**  
 (SAE versions with 4 bolt flange)

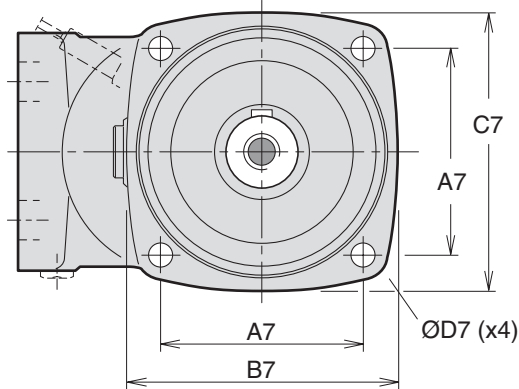

Type S (SAE 4 bolt) mounting flange

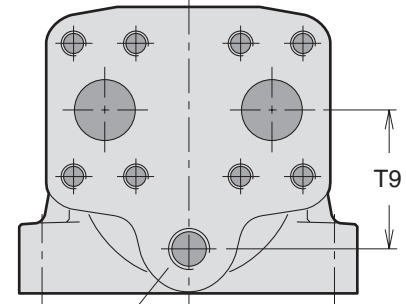

Port E (third drain port)  
 F12-110 barrel housing (SAE version)

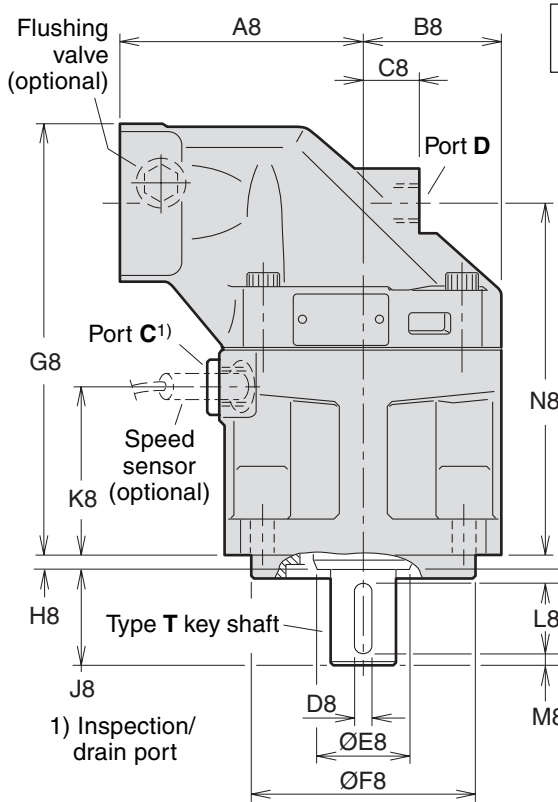

Shown: F12-80 with 4 bolt flange

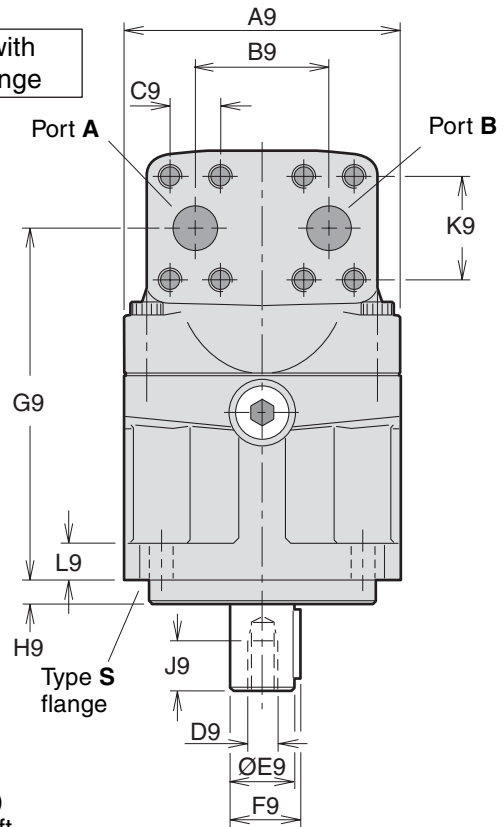

Dim.	F12-30	F12-40	F12-60	F12-80	F12-110
A7	89.8	114.5	114.5	114.5	161.6
B7	118	148	148	155	204
C7	118	144	144	155	200
D7	14	14	14	14	21
A8	100	110	125	135	145
B8	59	65	70	77.5	85
C8	25	26	22	32	38
D8	6.35	7.94	7.94	9.53	11.1
E8	33	42	42	52	57.5
F8	101.60/ 101.55	127.00/ 126.94	127.00/ 126.94	127.00/ 126.94	152.40/ 152.34
G8	189.5	197	214	240	264
H8	8	8	8	8	8
J8	38	48	48	54	67
K8	72	76	79	95	99
L8	31.8	38.1	38.1	44.5	54.1
M8	2.5	4	4	4	7.5
N8	153.5	161	178.3	197.1	212
Q8 <sup>1)</sup>	23	23	23	25	34
Q8 <sup>2)</sup>	-	-	-	23	-
R8 <sup>1)</sup>	33	48	48	54	66.7
R8 <sup>2)</sup>	-	-	-	48	-
A9	122	134	144	155	170
B9	66	66	66	75	83
C9	23.8	23.8	23.8	27.8	31.8
D9*	5/16"-24	3/8"-24	3/8"-24	1/2"-20	5/8"-18
E9	25.40/ 25.35	31.75/ 31.70	31.75/ 31.70	38.10/ 38.05	44.45/ 44.40
F9	28.2	35.3	35.3	42.3	49.4
G9	153.8	161	178.3	197.1	212
H9	9.7	12.7	12.7	12.7	12.7
J9	16	19	19	26	32
K9	50.8	50.8	50.8	57.2	66.7
L9	18	20	20	20	22
T9	-	-	-	-	68

\* UNF-2B thread

1) Spline shaft type **S**

2) " " " **U**

**Main ports A and B, type U (optional)**

F12-110	1 5/8" - 12 UN
---------	----------------

O-ring ports according to SAE J514d

Ports	F12-30	F12-40	F12-60	F12-80	F12-110
A, B size	3/4"	3/4"	3/4"	1"	1 1/4"
Screw thread <sup>3)</sup>	3/8"-16 x22	3/8"-16 x20	3/8"-16 x22	7/16"-14 x27	1/2"-13 x25
C thread	7/8"-14	7/8"-14	7/8"-14	7/8"-14	1 1/16"-12
D thread	3/4"-16	3/4"-16	7/8"-14	7/8"-14	1 1/16"-12
E thread	-	-	-	-	1 1/16"-12

A, B: ISO 6162

C, D, E: O-ring boss (SAE J514)

3) UN thread x depth in mm.

**Mounting flange (SAE J744)**

**S (standard)**      **X (optional)**

F12-30	S (standard)	X (optional)
-40	SAE 'B', 4 bolt	-
-60	SAE 'C', "	-
-80	SAE 'C', "	SAE 'D', 4 bolt
-110	SAE 'D', "	-

**Spline shaft (SAE J498b, class 1, flat root, side fit)**

**S (standard)**      **U (opt.)**      **X (optional)**

F12-30	S (standard)	U (opt.)	X (optional)
-40	SAE 'B' 13T, 16/32 DP	-	-
-60	SAE 'C' 14T, 12/24 DP	-	-
-80	SAE 'C-C' 17T, 12/24 DP	SAE 'C' 14T, 12/24 DP	SAE 'D' 13T, 8/16 DP
-110	SAE 'D' 13T, 8/16 DP	-	-

= Max 350 bar operating pressure.

**Key shaft (SAE J744)**

**T (standard)**      **X (optional)**

F12-30	T (standard)	X (optional)
-40	SAE 'B-B' (Ø25.4 mm/1")	-
-60	SAE 'C' (Ø31.75 mm/1 1/4")	-
-80	SAE 'C-C' (Ø38.1 mm/1 1/2")	SAE 'D' (Ø44.45 mm/1 3/4")
-110	SAE 'D' (Ø44.45 mm/1 3/4")	-

**F12-30, -40, and -60**

(SAE versions with 2 bolt flange)

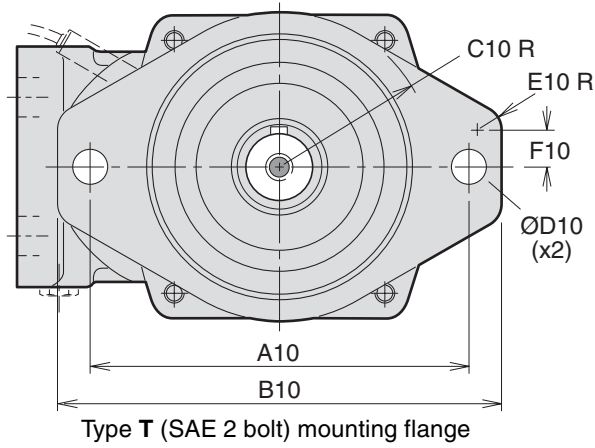

Shown: F12-60 with 2 bolt flange

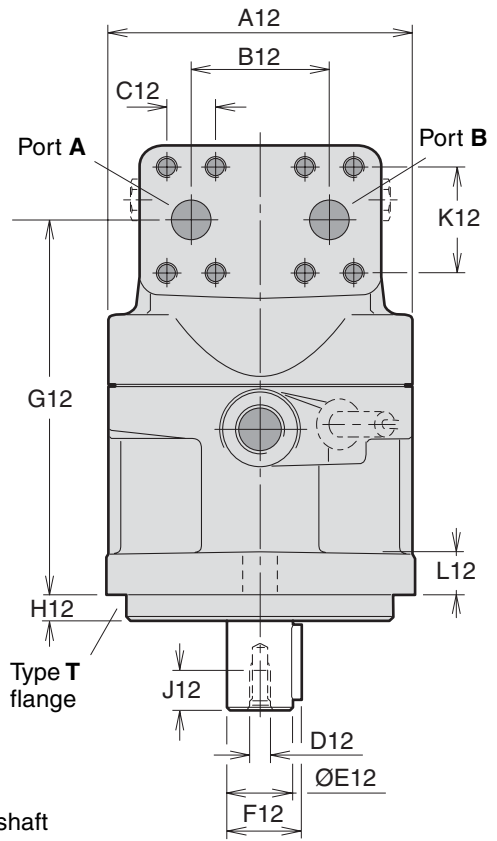
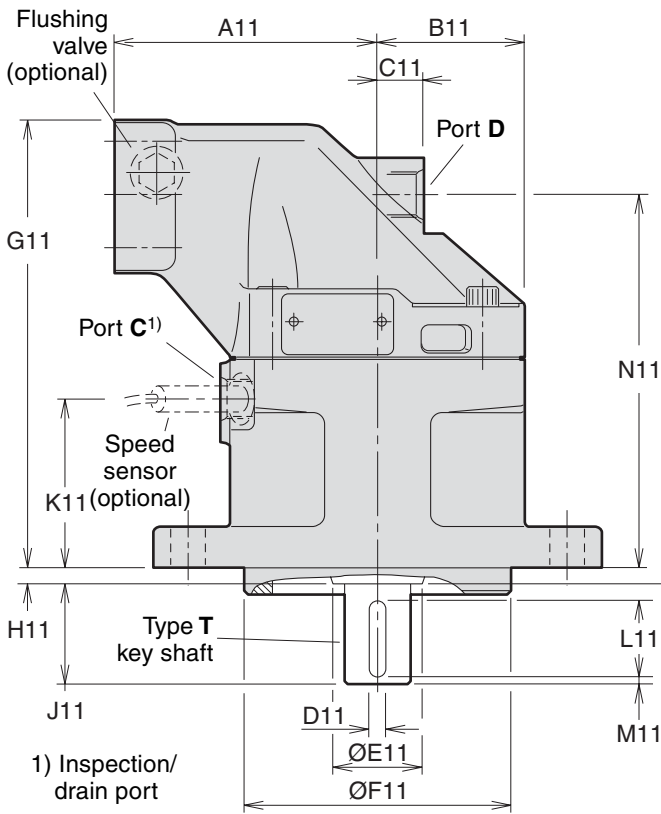

1) Inspection/  
drain port

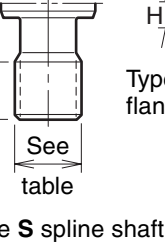

Dim.	F12-30	F12-40	F12-60
A10	146	181	181
B10	176	215	215
C10	63	74	74
D10	14.4	17.5	17.5
E10	10	16	16
F10	10	15.5	15.5
A11	100	110	125
B11	59	65	70
C11	25	26	22
D11	6.35	7.94	7.94
E11	33	42	42
F11	101.60/ 101.55	127.00/ 126.95	127.00/ 126.95
G11	189.5	197	214
H11	8	8	8
J11	38	48	48
K11	71	77	81.5
L11	31.8	38.1	38.1
M11	2.5	4	4
N11	154	161	178.5
Q11	26	27	27
R11	33	48	48
A12	122	134	144
B12	66	66	66
C12	23.8	23.8	23.8
D12 <sup>1)</sup>	5/16"-24	3/8"-24	3/8"-24
E12	25.40/ 25.35	31.75/ 31.70	31.75/ 31.70
F12	28.2	35.2	35.2
G12	154	161	178.5
H12	9.7	12.7	12.7
J12	16	19	19
K12	50.8	50.8	50.8
L12	18	20	20

1) UNF-2B thread

Ports	F12-30	F12-40	F12-60
A, B size	19 (3/4")	19 (3/4")	19 (3/4")
Screw thread <sup>2)</sup>	3/8"-16 x22	3/8"-16 x20	3/8"-16 x22
C thread	3/4"-16	3/4"-16	7/8"-14
D thread	3/4"-16	3/4"-16	7/8"-14

A, B (main ports): SAE J518c (6000 psi)

C, D (drain ports): O-ring boss (SAE J514)

2) UN thread

**Main ports A and B, type U (optional)**

F12-30	1 1/16" - 12 UN
-40	1 5/16" - 12 UN
-60	1 5/16" - 12 UN

O-ring ports according to SAE J514d

 = Max 350 bar operating pressure.

**Mounting flange T (SAE J744)**

F12-30	SAE 'B', 2 bolt
-40	SAE 'C', 2 bolt
-60	SAE 'C', 2 bolt

**Spline shaft S (SAE J498b, class 1, flat root, side fit)**

F12-30	SAE 'B' 13 T; 16/32 DP
-40	SAE 'C' 14 T; 12/24 DP
-60	SAE 'C' 14 T; 12/24 DP

**Key shaft T (SAE J744)**

F12-30	SAE 'B-B' Ø25.4 mm/1"
-40	SAE 'C' Ø31.75 mm/1 1/4"
-60	SAE 'C' Ø31.75 mm/1 1/4"

**F11-150**

(CETOP version)

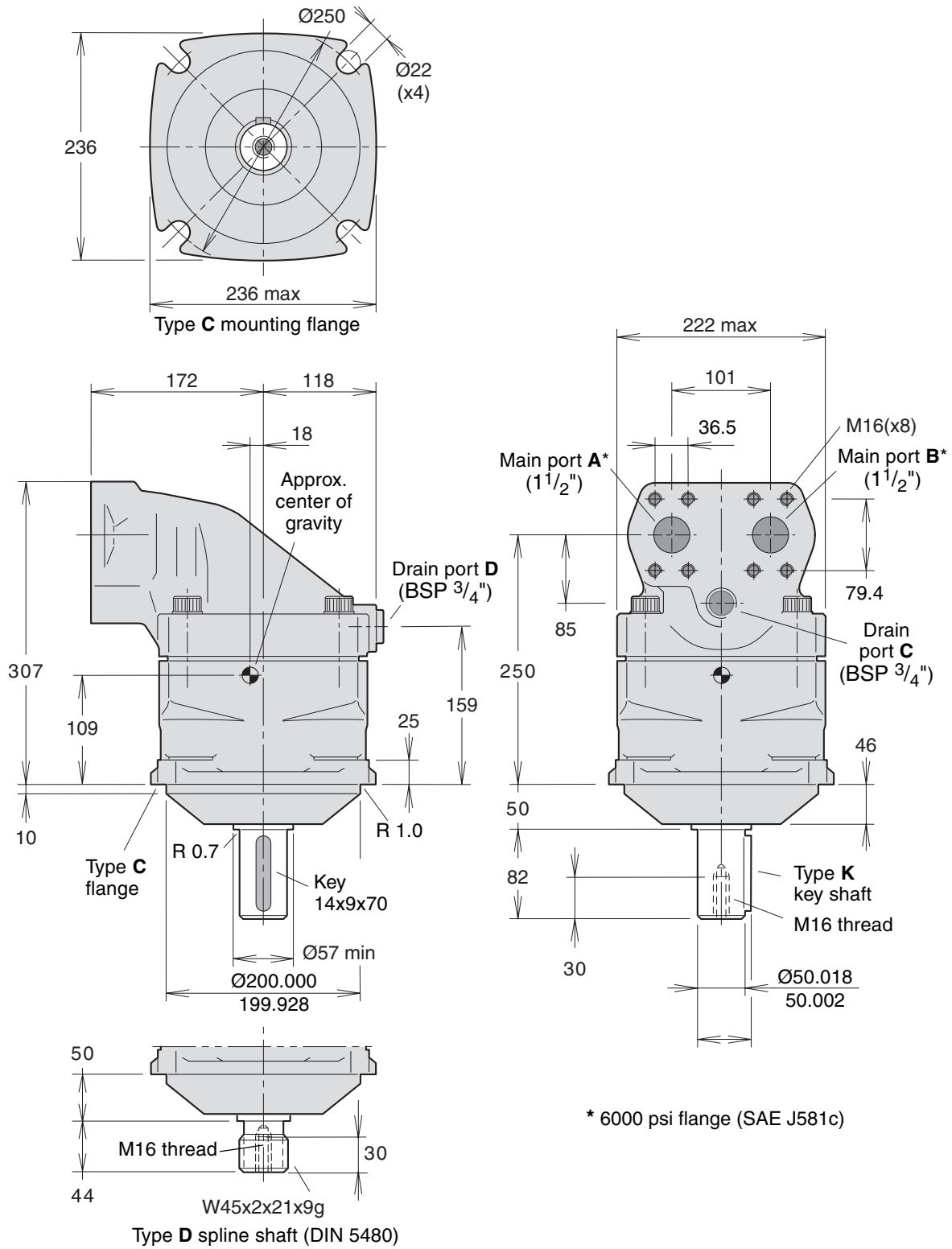



**F11-150**  
 (SAE version)

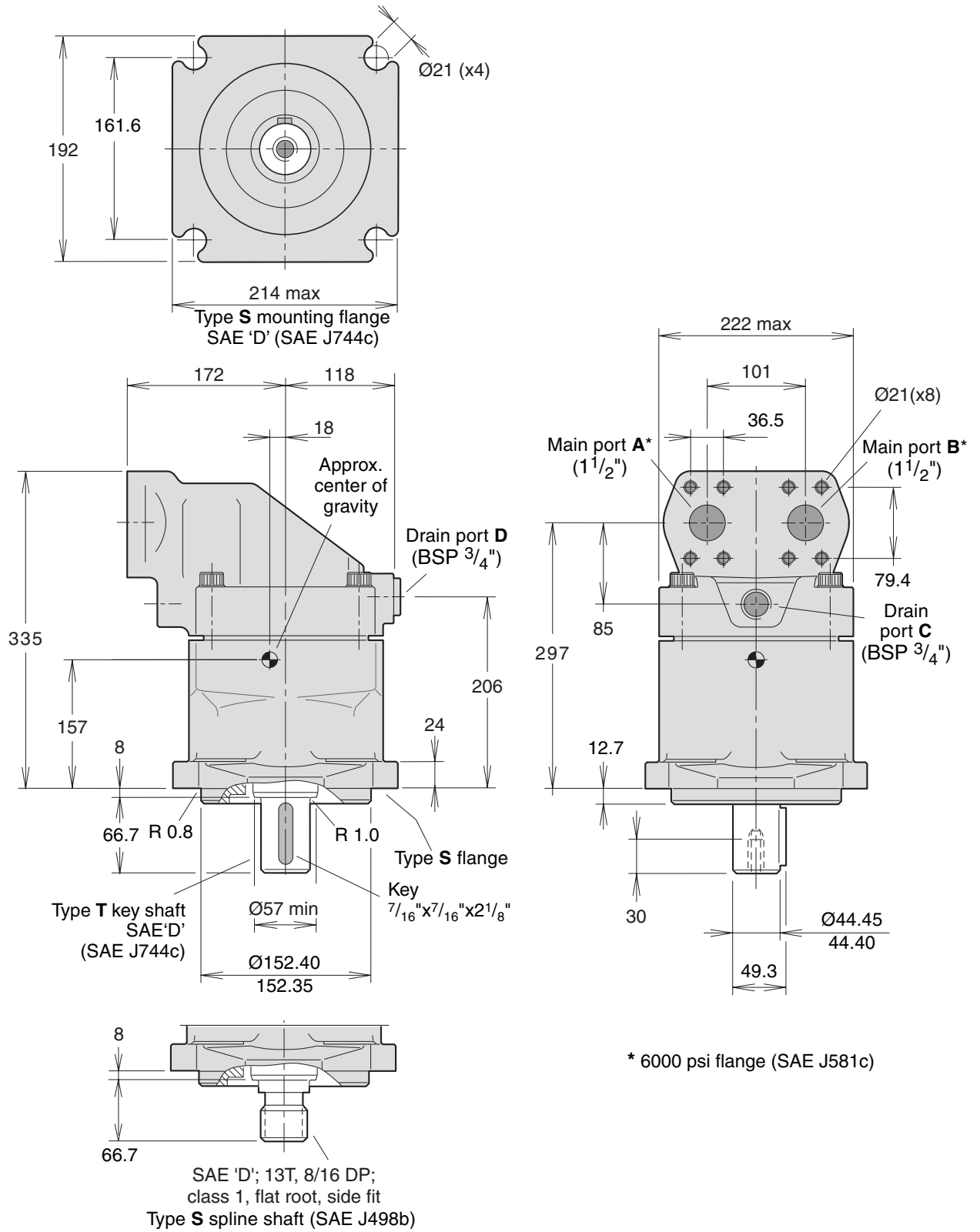

**F11-250**  
 (SAE version)

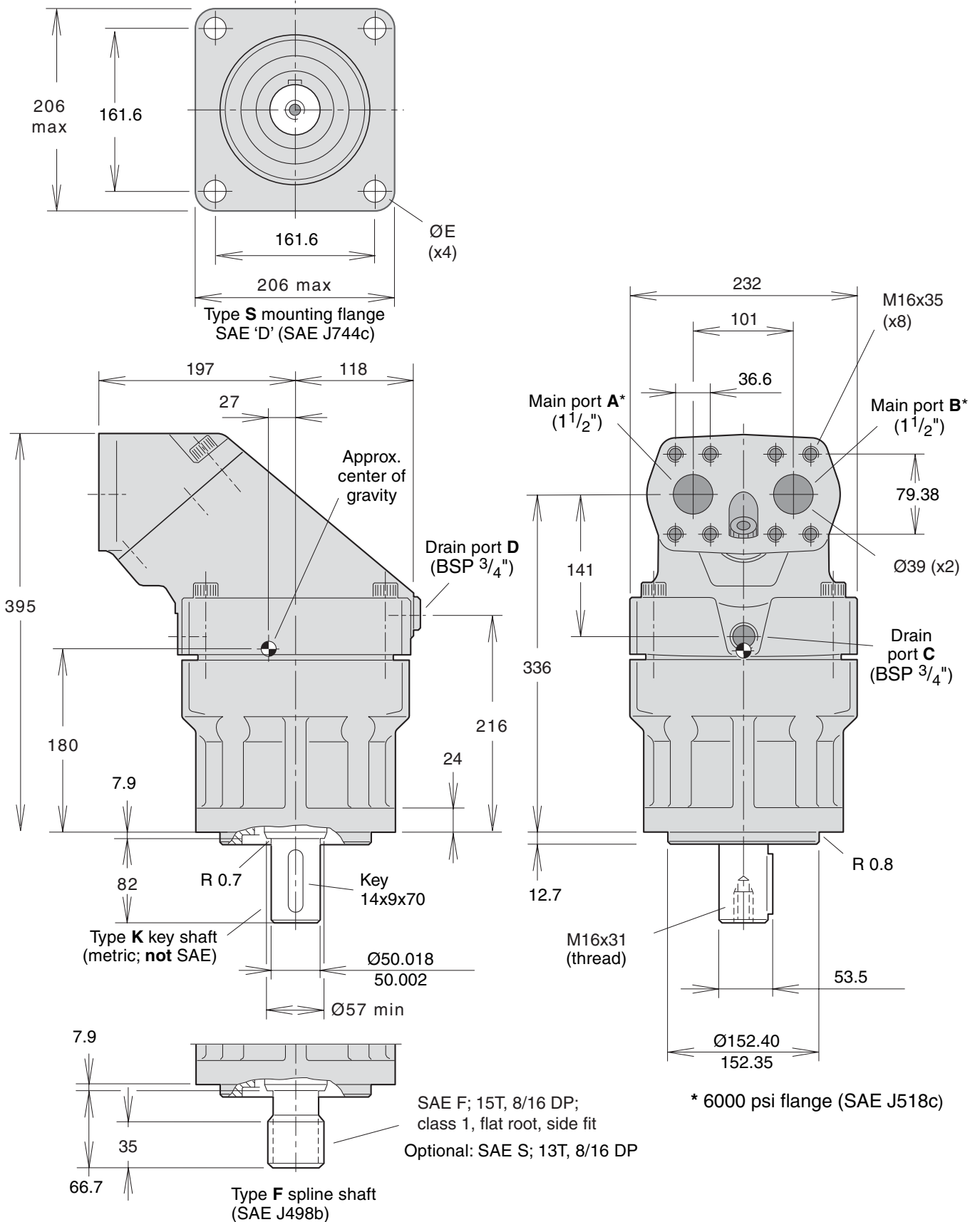

**F11 saw motors**

Series F11 motors have proven extremely reliable in demanding applications such as bar (chain) saws. Primarily due to the 40° bent-axis design, spherical pistons (with laminated piston rings) and gear synchronization, very high speeds are permissible. Not even low temperatures at start-up affect reliability.

To further enhance the saw function and, at the same time, reduce weight, cost and installation dimensions, a specific saw motor has been developed (frame sizes -10, -14 and -19; refer to the illustration to the right) which is specifically dedicated to bar saws. The motor allows the saw bar bearings to be mounted directly on the motor housing, and the spur gear installs on the motor shaft without any additional bearings.

For more detailed information (available versions, ordering codes, installation dimensions, etc.), refer to 'F11 Saw Motors' (catalogue 9129 8245-02).

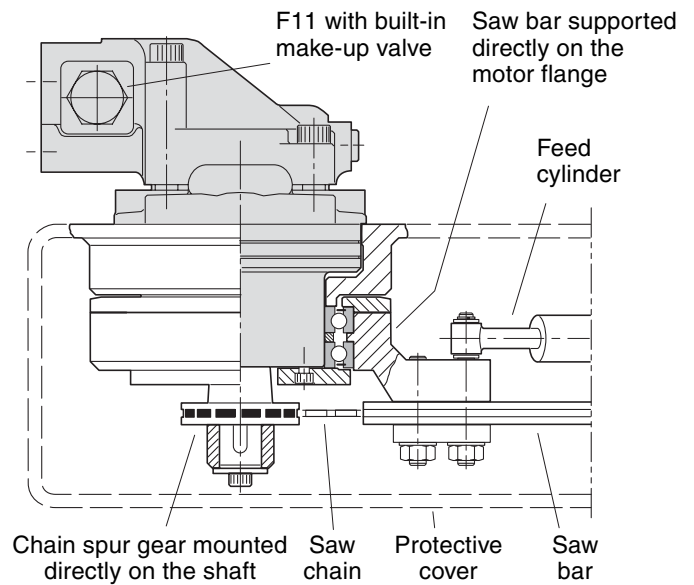

*Chain saw installation (example; F11-10 shown)*

**F11 fan motors**

Frame sizes -10, -14 and -19 are also available as 'fan motors' with a built-in check valve (refer to the schematic below) and CETOP mounting flange. Just like the saw motor, the fan motor can be operated at very high speeds without reliability problems. The fan is usually installed directly on the motor shaft without additional bearing support.

Additional information (available versions, ordering codes, installation dimensions, etc.) is available in publication 'F11 Fan Motors' (catalogue 9129 8247-02).

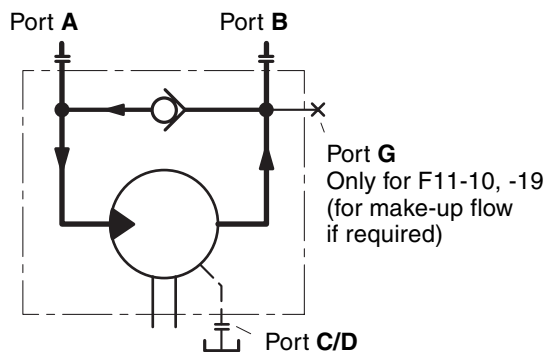

*Fan motor schematic (left hand rotation shown).*

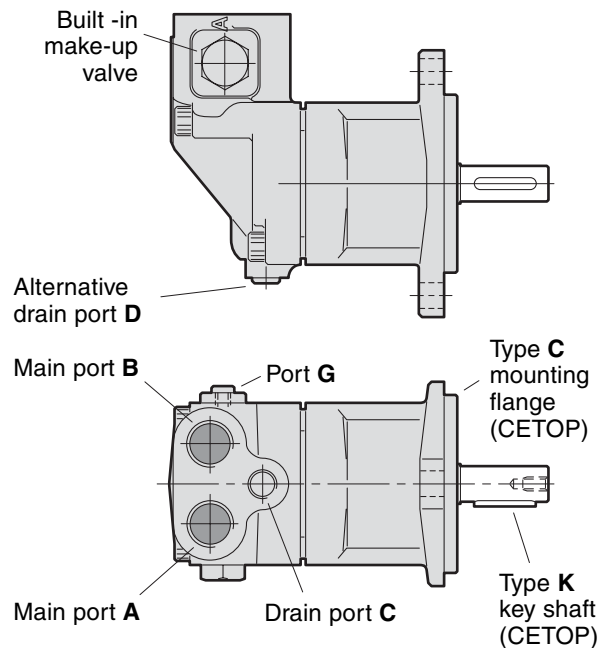

*Fan motor (F11-10 shown).*

**F12 integrated flushing valve**

(F12-30, -40, -60 and -80)

Series F12 (except F12-110; refer to the FV13 flushing valve block below) is available with an integrated flushing valve which provides the rotating parts with an additional cooling flow, required when operating at high speeds and power levels.

In a hydrostatic transmission, the valve also ensures that part of the main circuit fluid is being removed and replaced by cool, filtered fluid from the charge pump.

The flow is limited by a suitably sized nozzle that installes below a plug in the motor port flange.

**NOTE:** Ordering code, available nozzles and other information is provided in publication 'Mobile motor/pump accessories' (catalogue HY17-8258/UK).

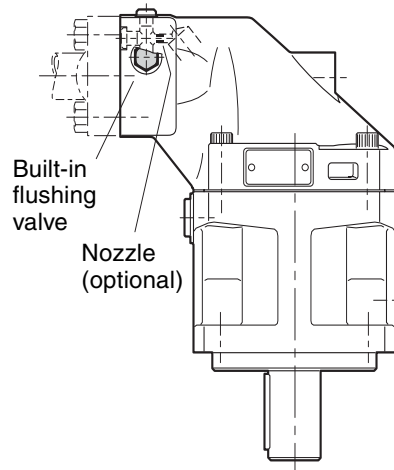

Integrated flushing valve (F12-30, -40, -60, -80) Nozzle (optional)

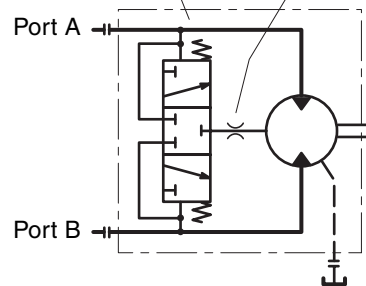

**F12 accessory valve blocks**

**Type FV13 flushing valve (for F12-110)**

A separate flushing valve block is available for the F12-110. It has the same function as the integrated valve for the other F12 frame sizes (above).

The valve block mounts between the motor port flange and the split flanges as shown to the right.

An optional nozzle can be installed in the valve block drain port.

Ordering code: FV13

**NOTE:** Additional information is available in publication 'Mobile motor/pump accessories' (catalogue HY17-8258/UK).

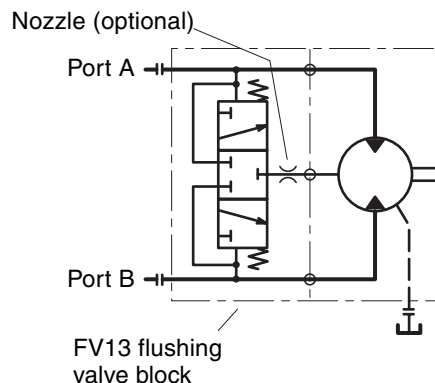
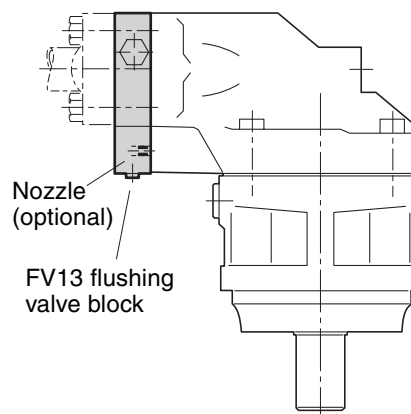

**Type BT brake valve**

When a motor (in an open loop system) is used in a hydrostatic vehicle transmission, the motor may operate faster than what corresponds to the available pump flow (e.g. in a steep downhill); this can lead to motor cavitation and loss of braking power.

The BT brake valve prevents cavitation by throttling the return flow from the motor as soon as the pressure level in the inlet port decreases to approximately 35 bar. At the same time, motor braking is provided when the pump flow decreases or is shut off.

The BT brake valve can be supplied with various optional functions such as a mechanical brake release valve and a flushing valve.

The valve block is very compact and installs between the motor port flange and the split flanges (refer to the illustration).

The BT valve block is available in two sizes:

- BT21 (3/4") for F12-30, -40, -60
- BT22 (1") for F12-80

**NOTE:** Detailed information on the BT valve is provided in publication 'Mobile motor/pump accessories' (catalogue HY17-8258/UK).

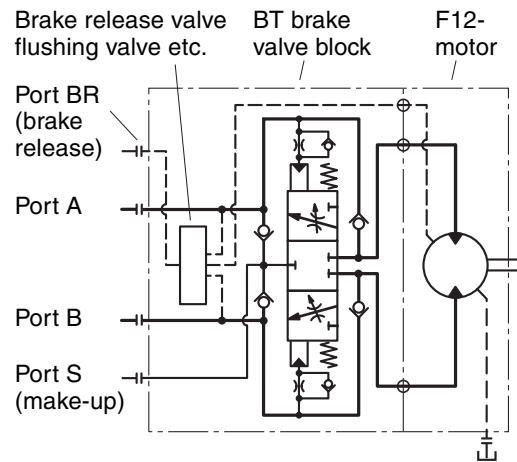
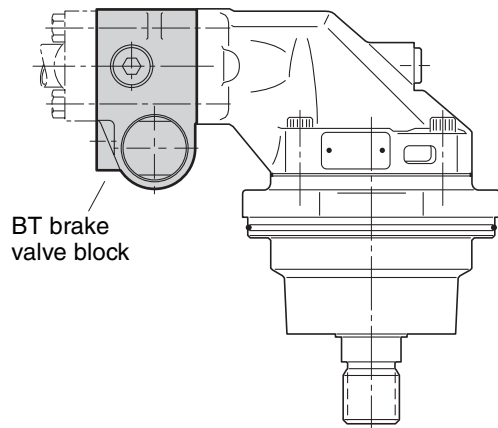

**Type SR pressure relief/make-up valve**

The SR pressure relief/make-up valve block for series F12 motors is designed to protect the motor from high pressure spikes as well as provide an excellent make-up function to help prevent motor cavitation (when port G is pressurized).

The valve block mounts between the motor port flange and the split flanges (as shown to the right).

The SR block is available in three sizes:

- SR11 (3/4") for F12-30, -40, -60
- SR12 (1") for F12-80
- SR13 (1 1/4") for F12-110

**NOTE:**

- For additional information such as pressure settings and installation dimensions, refer to publication 'Mobile motor/pump accessories' (catalogue HY17-8258/UK).
- To obtain a combined cross-over relief/make-up and flushing function on the F12-110, the SR13 and FV13 valve blocks can be stacked (with the flushing valve block mounted next to the motor).

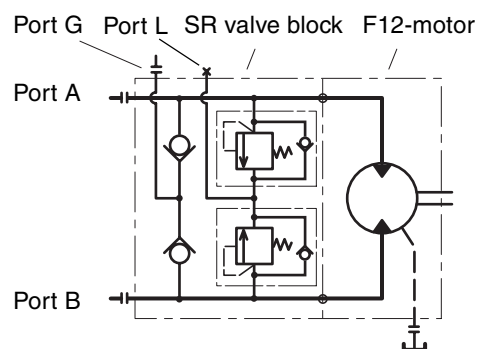
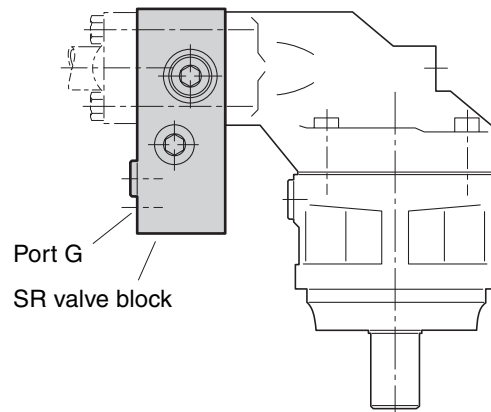

### Type SV pressure relief valve

The SV pressure relief valve for series F12 motors protects the motor and the corresponding main hydraulic lines from pressure spikes. Like the SR valve block (page 31), it has integrated cartridge type pressure relief valves and mounts between the motor port flange and the split flanges as shown to the right.

The design of the relief valves permits a limited make-up flow (when port L is pressurized).

The SV valve block is available in three sizes:

- SV11 (3/4") for F12-30, -40, -60
- SV12 (1") for F12-80
- SV13 (1 1/4") for F12-110

**NOTE:** - Detailed information on available pressure settings, installation dimensions, etc. is provided in publication 'Mobile motor/pump accessories' (catalogue HY17-8258/UK).

- On the F12-110, the FV13 flushing valve block (page 36) can be mounted between the SV13 block and the motor port flange to obtain a combined pressure relief and flushing function.

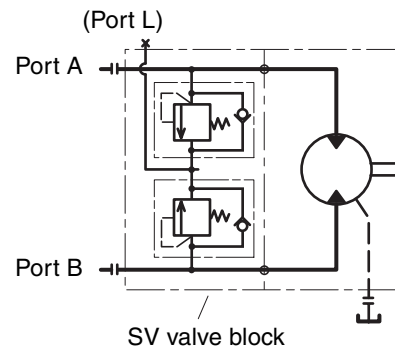
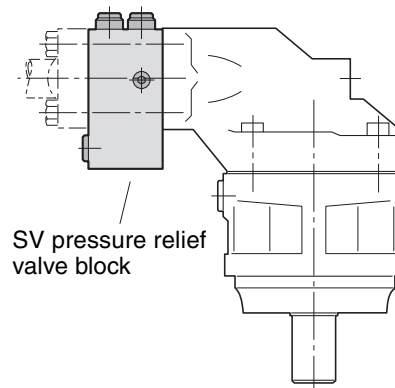

### Speed sensor

A speed sensor kit is available for series F11/F12. A ferromagnetic differential (Hall-effect) sensor installs in a separate, threaded hole in the F11/F12 bearing housing.

On F12 the speed sensor is directed towards the ring gear. On F11 the speed sensor is directed towards the pistons. The speed sensor outputs a square wave signal within a frequency range of 5 Hz to 20 kHz.

**NOTE:** - The motor bearing housing must be prepared for the speed pick-up; refer to the F11/F12 ordering codes (pages 7-12).

- On F11 **the pistons position must be known before mounting.**
- Additional information is provided in 'Mobile motor/pump accessories' (catalogue HY17-8258/UK).
- The speed sensor is also shown in the illustrations on pages 19, 21, 22, 24, 26 and 28.

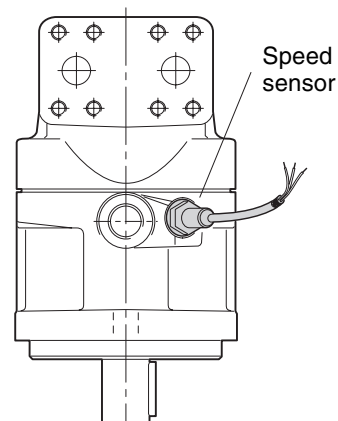

*F12 with speed sensor.*

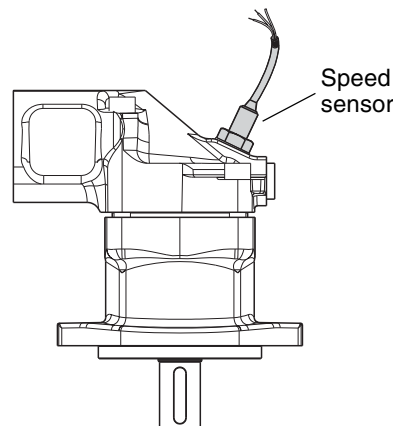

*F11-14 with speed sensor.*

## F12 main port suction fittings

### Suction fittings

To minimize the risk for cavitation when operating the F12 as a pump, we recommend using our suction fittings; all take 2" hoses.

Part no.	SAE size	For	L [mm]
379 4070	3/4"	F12-30 F12-40 F12-60	100
370 4095	1"	F12-80	100
370 3916	1 1/4"	F12-110	102

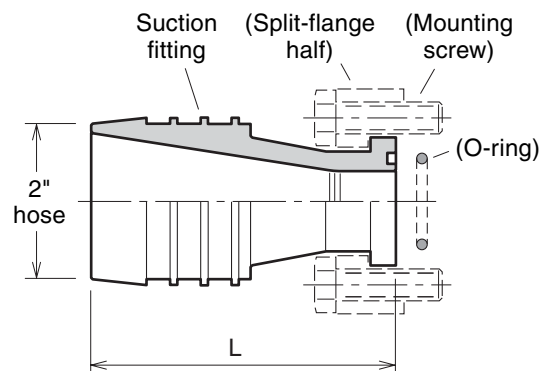

The suction fittings are designed for use with standard SAE or metric split-flange halves as shown. O-ring and mounting screw sizes are listed below.

SAE size	O-ring dimension	Screw size	
		SAE	Metric
3/4"	30.0x3.53	3/8"-16x1.50	M10x35
1"	32.9x3.53	7/16"-14x1.50	M12x40
1 1/4"	37.7x3.53	1/2"-13x1.75	M14x45

### Suction fitting kits

Suction fitting kits are available for the F12 ISO and Cartridge versions. A kit consists of a suction fitting (shown above), two split-flange halves, an O-ring and four mounting screws.

Part no.	SAE size	For	Screw size
379 4421	3/4"	F12-30/-40/-60	M10x35
370 4098	1"	F12-80	M12x40
370 3926	1 1/4"	F12-110	M14x45

### Split-flange kits

Separate metric split-flange kits, consisting of two split-flange halves and four mounting screws for use on the F12 ISO and cartridge versions, are also available.

Part no.	SAE size	For	Screw size
379 4405	3/4"	F12-30/-40/-60	M10x35
370 4329	1"	F12-80	M12x40
370 4330	1 1/4"	F12-110	M14x45

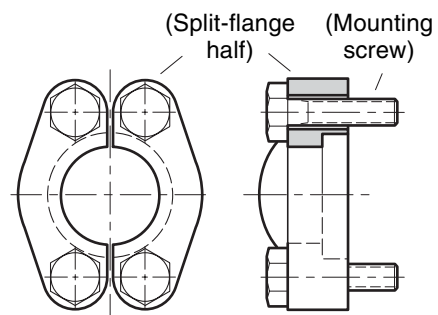

**Direction of rotation**

The M and H versions of series F11, and the M version of series F12, are bi-directional.

The L and R pump versions are uni-directional, allowing higher selfpriming speeds (refer to page 14).

The illustration to the right shows direction of flow versus shaft rotation. In a motor application, the shaft turns clockwise when port **B** (black arrow) is pressurized, and counter clockwise when port **A** (open arrow) is pressurized.

In a pump application where the shaft turns clock-wise, port B is the inlet port and should be connected to tank; when the shaft turns counter clockwise, port A is the inlet port.

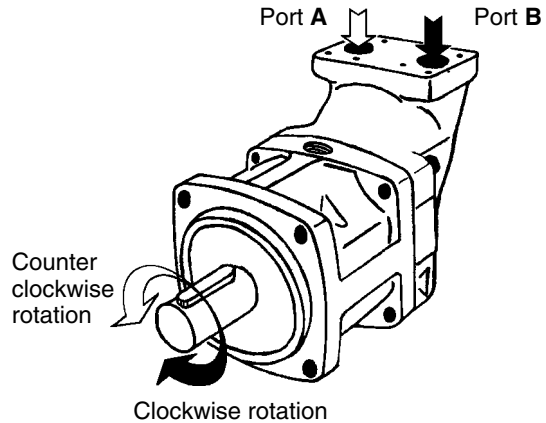

**Hydraulic fluids**

Ratings and performance data for series F11/F12 are based on operating with good quality, contamination-free, petroleum-based fluids.

Hydraulic fluids type HLP (DIN 51524), automatic transmission fluids type A, or API CD engine oils can be used.

Fire resistant fluids (when used under modified operating conditions) and synthetic fluids may also be suitable.

For additional information, refer to Hydraulic Marketing IS data base:

- Hydraulic fluid specifications
- Fire resistant fluids.

**Operating temperature**

The following temperatures should not be exceeded (type **H** and **N** shaft seals):

Drain fluid: 90 °C.

FPM shaft seals ( type **E**, type **V**) can be used to 115 °C drain fluid temperature.

**NOTE:** The temperature should be measured at the utilized drain port.

Continuous operation may require case flushing in order to meet the viscosity and temperature limitations.

The following table shows operating speeds, above which flushing is usually required, as well as suggested flow through the case.

**NOTE:**

When operating the F11/F12 as a pump above the selfpriming speed (valid for both the pump and motor versions), the inlet must be sufficiently pressurized. Increased noise and deteriorating performance may otherwise be experienced.

For further information refer to 'Selfpriming speed and required inlet pressure' on page 6.

**Series F11**

Frame size	Speed [rpm]	Flow [l/min]
F11-5	5500	1-2
F11-10	4500	2-3
F11-14	4500	2-3
F11-19	4000	2-4
F11-150	2200	10-20
F11-250	1800	12-22

**Series F12**

Frame size	Speed [rpm]	Flow [l/min]
F12-30	3500	4-8
F12-40	3000	5-10
F12-60	3000	7-14
F12-80	2500	8-16
F12-110	2300	9-18



**Viscosity**

The ideal operating range is 15 to 30 mm<sup>2</sup>/s [cSt].  
 At operating temperature, the viscosity (of the drain fluid) should be kept above 8 mm<sup>2</sup>/s [cSt].  
 At start-up, the viscosity should not exceed 1000 mm<sup>2</sup>/s [cSt]

**Filtration**

To obtain the highest service life of the F11/F12, the fluid cleanliness should meet or exceed ISO code 18/13 (ISO 4406).  
 During normal operating conditions, a 10 µm (absolute) filter is recommended.

**Case pressure**

The tables below show the highest recommended case pressure as a function of shaft speed.  
 'Nominal' shaft seal life can be expected at a certain speed and the corresponding max case pressure. Seal life will be shorter, however, at unfavourable operating conditions (high temperature, low oil viscosity, contaminated oil).

**Series F11**

Max case pressure [bar] versus shaft speed [rpm]

Speed Shaft seal	1500		3000		4000		5000		6000		8000		9000		10000		11000		12000	
	H/V	N/E	H/V	N/E	H/V	N/E	H/V	N/E	H/V	N/E	H/V	N/E	H/V	N/E	H/V	N/E	H/V	N/E	H/V	N/E
F11-5	20	2.2	13	1.9	10	1.6	8	1.3	6.5	0.9	5	0.6	4.2	0.5	4	0.3	3.5	0.2	3	0
F11-10	20	2.2	11.5	1.8	8.5	1.2	7	1.0	5.5	0.7	4	0.5	3.8	0.4	3.5	0.2	3.0	0	-	-
F11-14	19	2.2	9.5	1.5	7	1.0	5.5	0.8	4.5	0.5	3.5	0.4	3.0	0.2	2.5	0	-	-	-	-
F11-19	19	2.2	9.5	1.4	7	0.9	5.5	0.6	4.5	0.4	3.5	0.3	3.0	0	-	-	-	-	-	-
F11-150	9.5	2.2	4.5	0.6	-	-	-	-	-	-	-	-	-	-	-	-	-	-	-	-
F11-250	9.5	-	4.5	-	-	-	-	-	-	-	-	-	-	-	-	-	-	-	-	-

Max recommended case pressure versus shaft speed - F11 seal types **H** or **V** and **N** or **E**.

**Series F12**

Max case pressure [bar] vs. shaft speed [rpm]

Speed Shaft seal	1500		3000		4000		5000		6000	
	H/V	N	H/V	N	H/V	N	H/V	N	H/V	N
F12-30	14	2.2	7	1.4	5.5	0.9	4.5	0.6	3.5	0.2
F12-40	12	2.2	6	1.2	4.5	0.7	3.5	0.4	-	-
F12-60	12	2.2	6	1.2	4.5	0.7	3.5	0.4	-	-
F12-80	10	2.2	5	0.8	4	0.4	-	-	-	-
F12-110	9.5	2.2	4.5	0.6	-	-	-	-	-	-

Max recommended case pressure versus shaft speed - F12 seal types **H** or **V**, and **N**

**Case drain connections**

Series F11/F12 have two drain ports, **C** and **D**, while F12-110 has an additional port, **E**.

The uppermost drain port (such as port **C** in the illustration below) should always be utilized.

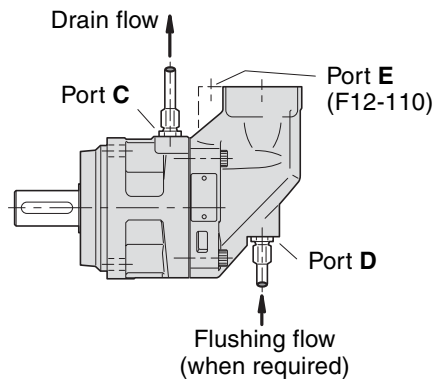

In mounting positions such as 'shaft up' (below) a spring loaded check valve should be installed in the drain line in order to insure a sufficiently high oil level in the case.

Preferably, the drain line should be connected directly to the reservoir.

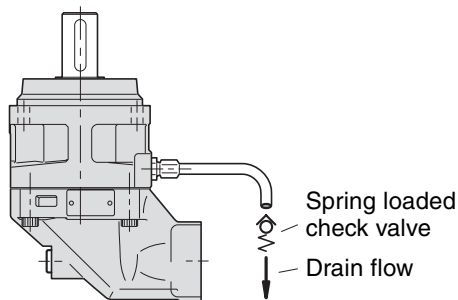
**Before start-up**

Make sure the F11/F12 case as well as the entire hydraulic system is filled with a recommended fluid.

The internal leakage, especially at low operating pressures, is *not* sufficient to provide lubrication at start-up.

**NOTE:**

- To avoid cavitation and obtain a low noise level as well as reduced heat generation, tubes, hoses and fittings must be adequately dimensioned.
- Preferably, the suction line flow speed should be 0.5 to 1 m/s, and pressure line flow speeds 3 to 5 m/s.
- For series F12, suitable suction fittings are available (refer to page 39).



## **WARNING**

**FAILURE OR IMPROPER SELECTION OR IMPROPER USE OF THE PRODUCTS AND/OR SYSTEMS DESCRIBED HEREIN OR RELATED ITEMS CAN CAUSE DEATH, PERSONAL INJURY AND PROPERTY DAMAGE.**

This document and other information from Parker Hannifin Corporation, its subsidiaries and authorized distributors provide product and/or system options for further investigation by users having technical expertise. It is important that you analyze all aspects of your application, including consequences of any failure, and review the information concerning the product or system in the current product catalogue. Due to the variety of operating conditions and applications for these products or systems, the user, through its own analysis and testing, is solely responsible for making the final selection of the products and systems and assuring that all performance, safety and warning requirements of the application are met.

The products described herein, including without limitation, product features, specifications, designs, availability and pricing, are subject to change by Parker Hannifin Corporation and its subsidiaries at any time without notice.

## **Offer of Sale**

Please contact your Parker representation for a detailed "Offer of Sale".

# Hydraulics Group Sales Offices

## Europe

**Austria**  
**Wiener Neustadt**  
Tel: +43 (0)2622 23501  
Fax: +43 (0)2622 66212

**Belgium**  
**Nivelles**  
Tel: +32 (0)67 280 900  
Fax: +32 (0)67 280 999

**Czech Republic**  
**Prague**  
Tel: +420 2 830 85 221  
Fax: +420 2 830 85 360

**Denmark**  
**Ballerup**  
Tel: +45 4356 0400  
Fax: +45 4373 8431

**Finland**  
**Vantaa**  
Tel: +358 (0)9 4767 31  
Fax: +358 (0)9 4767 3200

**France**  
**Contamine-sur-Arve**  
Tel: +33 (0)450 25 80 25  
Fax: +33 (0)450 03 67 37

**Germany**  
**Kaarst**  
Tel: +49 (0)2131 4016 0  
Fax: +49 (0)2131 4016 9199

**Hungary**  
**Budapest**  
Tel: +36 (06)1 220 4155  
Fax: +36 (06)1 422 1525

**Ireland**  
**Dublin**  
Tel: +353 (0)1 293 9999  
Fax: +353 (0)1 293 9900

**Italy**  
**Corsico (MI)**  
Tel: +39 02 45 19 21  
Fax: +39 02 4 47 93 40

**The Netherlands**  
**Oldenzaal**  
Tel: +31 (0)541 585000  
Fax: +31 (0)541 585459

**Norway**  
**Ski**  
Tel: +47 64 91 10 00  
Fax: +47 64 91 10 90

**Poland**  
**Warsaw**  
Tel: +48 (0)22 863 49 42  
Fax: +48 (0)22 863 49 44

**Portugal**  
**Leca da Palmeira**  
Tel: +351 22 9997 360  
Fax: +351 22 9961 527

**Slovakia**  
*Ref. Czech Republic*

**Spain**  
**Madrid**  
Tel: +34 91 675 73 00  
Fax: +34 91 675 77 11

**Sweden**  
**Spånga**  
Tel: +46 (0)8 597 950 00  
Fax: +46 (0)8 597 951 10

**United Kingdom**  
**Warwick**  
Tel: +44 (0)1926 317 878  
Fax: +44 (0)1926 317 855

## International

**Australia**  
**Castle Hill**  
Tel: +61 (0)2-9634 7777  
Fax: +61 (0)2-9899 6184

**Canada**  
**Milton, Ontario**  
Tel: +1 905-693-3000  
Fax: +1 905-876-0788

**China**  
**Beijing**  
Tel: +86 10 6561 0520  
Fax: +86 10 6561 0526

**Asia Pacific Group**  
**Hong Kong, Kowloon**  
Tel: +852 2428 8008  
Fax: +852 2425 6896

**India**  
**Mumbai**  
Tel: +91 22 7907081  
Fax: +91 22 7907080

**Japan**  
**Tokyo**  
Tel: +(81) 3 6408 3900  
Fax: +(81) 3 5449 7201

**Latin America Group**  
**Brazil**  
Tel: +55 12 3954-5100  
Fax: +55 12 3954-5266

**South Africa**  
**Kempton Park**  
Tel: +27 (0)11-961 0700  
Fax: +27 (0)11-392 7213

**USA**  
**Cleveland (industrial)**  
Tel: +1 216-896-3000  
Fax: +1 216-896-4031  
**Otsego (mobile)**  
Tel: +1 269-694-9411  
Fax: +1 269-694-4638

**Parker Hannifin is the world's premier supplier of motion and control systems and solutions, with sales and manufacturing facilities throughout the world. For product information and details of your nearest Parker sales office, visit us at [www.parker.com/euro\\_mcd](http://www.parker.com/euro_mcd) or call free on 00800 2727 5374.**



Catalogue HY17-8249/UK  
4M 03/04 RT

© Copyright 2004  
Parker Hannifin Corporation  
All rights reserved.